

B.S.A.

Motor Cycle Instruction Book

All models 1930 to 1936
inclusive



Price 6d.

Handwritten text, possibly a name or title, in the top left corner.

Instruction Book for B.S.A. Motor Cycles.

1930 to 1936 Inclusive.

FILLING-UP.

The petrol tank capacity varies with different models. Fill the oil tank, which will be found either under the saddle, or in the sump or in a separate compartment in the petrol tank, according to the model and year of manufacture.

To obtain the most satisfactory service from your machine, it is most essential to use only high quality lubricants. This point cannot be over-emphasized. For correct lubrication we strongly recommend the high quality oils tabulated below. It is not sufficient merely to specify the grade but the actual brand required must be stated. Drain and refill the oil compartment every 1,000 miles on models with sump and dry sump lubrication. Top up every 250 miles.

	Wakefield	Vacuum	Shell	Essolube	Price's
Summer	Patent Castrol XXL	Mobiloil Clearsol D	Aero- shell	Racer	Motorine B de Luxe
Winter..	Patent Castrol XL	Mobiloil Clearsol D	Aero- shell	Racer	Motorine C de Luxe

In the case of the 1.74 h.p. two-stroke the engine is lubricated by the Petroil system, and for this

www.rpw.it

purpose the lubricating oil is mixed with the petrol. For every gallon of petrol poured into the tank add 1.1/3 charges of lubricating oil from the filler cap measure.

Check the oil in the gearbox and make certain that all other parts are adequately lubricated.

CONTROLS.

The carburetter controls are on the right handlebar. On some machines the throttle is operated by twist grip, in which case the air lever is mounted just above the front brake lever, while on others without twist grip control the throttle is operated by the longer of the two levers mounted together immediately above the front brake lever.

On the left handlebar will be found the ignition control (either lever or twist-grip), clutch lever and exhaust valve lifter. This latter control is replaced by a decompressor on the 1.74 h.p. two stroke.

The twist grips open the throttle, or advance the ignition by turning towards the rider.

The rear brake is operated by either a left or right toe pedal on all models except the 9.86 h.p. S.V. twin, which has a left heel pedal, while the front brake is operated by a lever on the right handlebar.

The positions of the foot and hand gear control levers are marked with their appropriate numbers, i.e., "1" for first gear, etc.

STARTING.

Set the throttle at about one eighth open and the air lever shut. Move the ignition control to about one half full advance. Raise the exhaust lifter (or

decompressor in the case of 1.74 h.p.), push the kickstarter down as smartly as possible with the foot, and when it is just over half way down drop the exhaust lifter.

With the larger engines, first depress the kickstarter until compression is felt. Then raise the exhaust lifter and depress the kickstarter about another quarter of its travel. Allow the kickstarter to return to its top position, and without rising the exhaust lifter give the pedal a vigorous kick downwards. In cold weather flood the carburetter by depressing the tickler for a short time only, since excessive flooding will make starting difficult. Now move the ignition control to the fully advanced position. As soon as the engine is warm open the air lever about three-quarters of its travel. It is unnecessary to disturb this control unless the engine knocks when the control should be closed slightly.

GEAR CHANGING.

To obtain first gear, raise the clutch lever fully and push the gear lever into the forward position with a hand-change or upwards with a foot-change. Engage the clutch gently and at the same time gradually open the throttle. When the machine is well under way change into second gear in a similar manner but by declutching again and pulling the hand lever back or by pushing the foot pedal down, then into third gear (if four-speed gearbox is fitted), and finally into top gear. To change down, first raise the clutch lever, and then move the gear lever in the reverse order to the above. To change perfectly it is necessary to accelerate the engine when changing down and to slow it down when changing up.

LUBRICATION.

A number of different lubrication systems have been applied to B.S.A. motor cycles and a careful study of the system applicable to any particular machine will be amply repaid by increasing the life of the engine.

PETROIL SYSTEM. The only model on which this system has been used is the 1930 1.74 h.p. two-stroke. The lubricating oil (see chart on page 1) is mixed with the petrol, and mixture of the correct proportions can be prepared conveniently if the measure combined with the petrol tank filler cap is used. **For every gallon of petrol add 1.1/3 charges of oil.** It is advisable to rock the

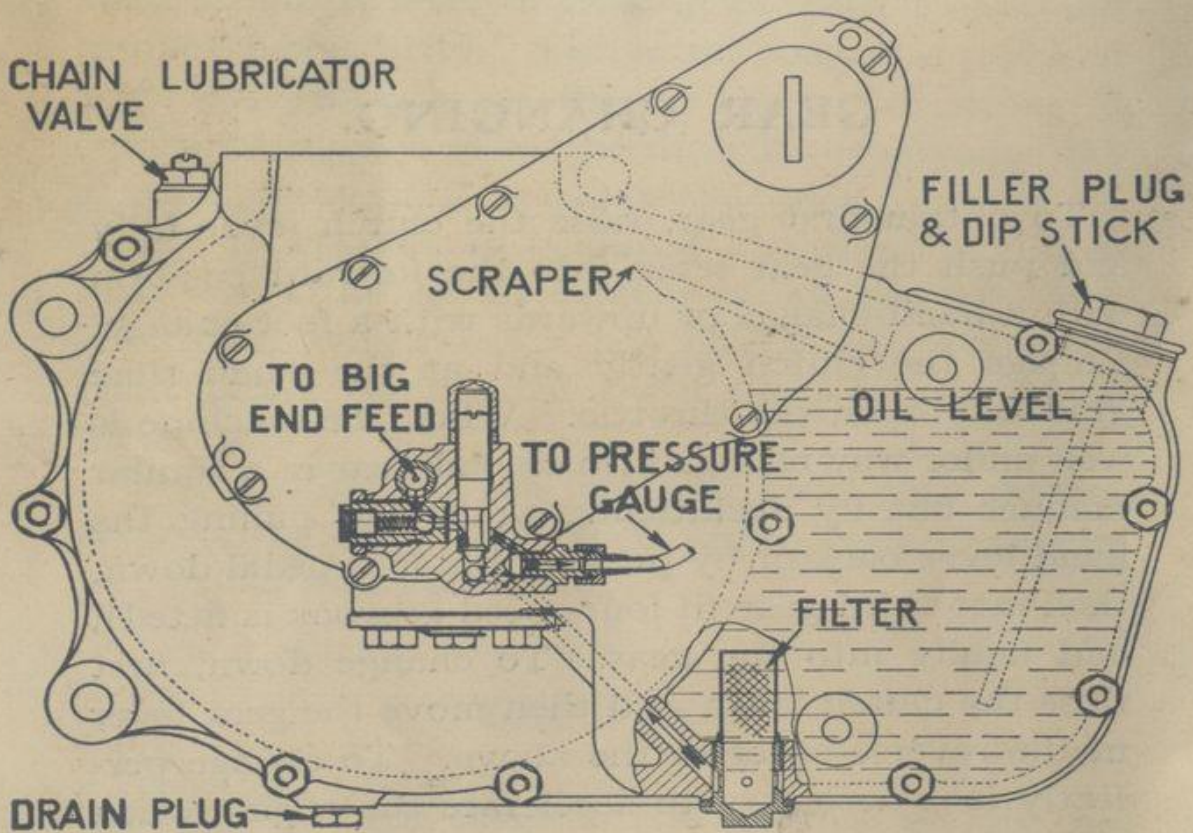

Fig. 1.

machine sideways or to stir the contents of the tank after filling up, in order to mix the petrol and oil thoroughly.

“SUMP” SYSTEM (Fig. 1). Cast integral with the crankcase is a sump, the capacity of which varies with different models. The gear type pump, driven by skew gearing from the timing side mainshaft, delivers filtered oil to the big-end bearing, the oil entering the annular space between the two rows of rollers and the centre portion of the phosphor bronze cage.

Any excess of oil is picked up by the flywheel rims from the bottom of the crankcase and is removed by a scraper acting on the flywheels and returned to the sump.

The oil supply is controlled by a valve on the delivery side of the pump on upright engined models, but on machines with inclined engines the valve is on the intake side of the pump and is provided with an extension handle passing in front of the timing case. For ordinary running this valve should be opened from half to one complete turn anti-clockwise. This setting is only arbitrary and the rider should find out for himself the most economical setting consistent with adequate lubrication.

On those models which have an oil pressure gauge, the normal reading when starting up should be 8-15 lbs. per square inch, and as the oil warms this falls to 3-9 lbs. per square inch. If the reading with a normal setting of the oil control falls much below this it is essential that the oiling system be checked over, first ascertaining that the sump contains oil.

On models not fitted with an oil pressure gauge, a tell-tale is mounted on the timing cover. This takes the form of a small spring loaded plunger, which is forced outwards by the passage of oil, and so long as the pump is working, the tell-tale should project about a quarter of an inch. If it moves out further than this, the setting should be reduced, but if it moves in and out continuously instead of remaining stationary, the engine is not receiving enough oil. Check the oil level in the sump.

An oil level dipper gauge is attached to the sump filler cap on vertical engined models, the gauge having pint graduations marked on its flat side. To test the oil level, wipe the gauge clean, re-insert it, and withdraw it again, when the oil level will be clearly marked. On inclined engine models the dipper gauge is separate from the filler cap, is of the quick-release type and is fitted on the right-hand side of the sump. When the oil level falls to the notch marked $\frac{1}{2}$ or 1 (according to the model) the sump should be filled up with half-a-pint or one pint of oil as the case may be. **It is of the utmost importance, however, not to run more than about 20 miles after the oil level has fallen to the lower mark ($1\frac{1}{2}$ on smaller engines and 2 on larger engines).** If this distance is exceeded engine trouble may occur due to lack of lubrication.

When an auxiliary oil tank, together with pedal operated force feed pump, is fitted to the machine, this provides an additional supply of oil direct to the piston.

The oil sump should be drained about every 1,000 miles, preferably when the engine is warm and the filter cleaned. Use flushing oil or thin machine oil for flushing out the crankcase, but **do not use paraffin.**

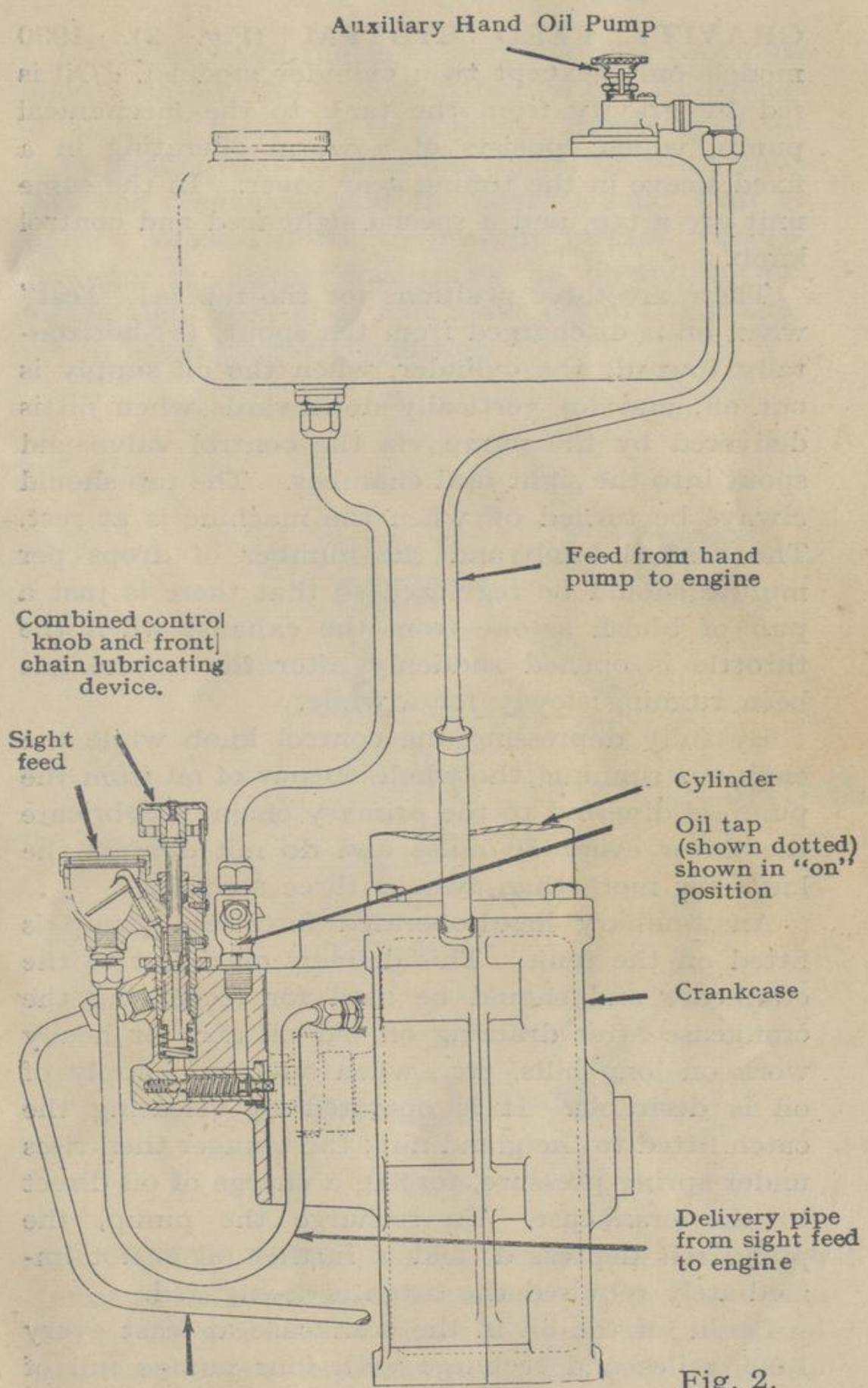

Auxiliary Hand Oil Pump

Feed from hand pump to engine

Combined control knob and front chain lubricating device.

Sight feed

Cylinder

Oil tap (shown dotted) shown in "on" position

Crankcase

Delivery pipe from sight feed to engine

Delivery pipe from mechanical pump to front chain

Fig. 2.

www.rpw.it

GRAVITY FEED SYSTEM (Fig. 2). 1930 models only (except twin cylinder models). Oil is fed by gravity from the tank to the mechanical pump, which consists of a worm operating in a fixed sleeve in the timing gear cover. In the same unit are a tap, and a special sight feed and control knob.

There are three positions for the tap (a) "Test" when oil is discharged from the spout, (b) horizontally towards the cylinder, when the oil supply is cut off, and (c) vertically downwards when oil is delivered by the pump via the control valve and spout into the sight feed chamber. The tap should always be turned off when the machine is at rest. The control knob and the number of drops per minute should be regulated so that there is just a puff of bluish smoke from the exhaust when the throttle is opened suddenly after the engine has been running slowly for a while.

By fully depressing the control knob while the engine is running, the whole output of oil from the pump is diverted to the primary chain. Lubricate the latter every 50 miles and do not depress the knob for more than two or three seconds.

An auxiliary hand-operated force-feed pump is fitted on the tank. This delivers oil direct to the crankcase and should be used for recharging the crankcase after draining off old oil and for heavy work on long hills, etc., when an extra supply of oil is desirable. It is operated by releasing the catch fitted to the gland nut; the plunger then rises under spring pressure, forcing a charge of oil direct to the crankcase. To recharge the pump, the plunger is depressed, and if further oil is not immediately required the catch is re-engaged.

Drain off the oil in the crankcase at least every 1,000 miles and recharge with four pumps full of fresh oil.

In the event of the sight feed chamber becoming filled with oil, this will probably be due to leakage of air past the sight feed glass. Removal of the sight feed cover will allow the excess of oil to drain into the crankcase, and the cover should then be tightly screwed down to prevent further leakage. Examine the leather washers at the top and bottom of the sight feed glass and make certain that they are in a satisfactory condition.

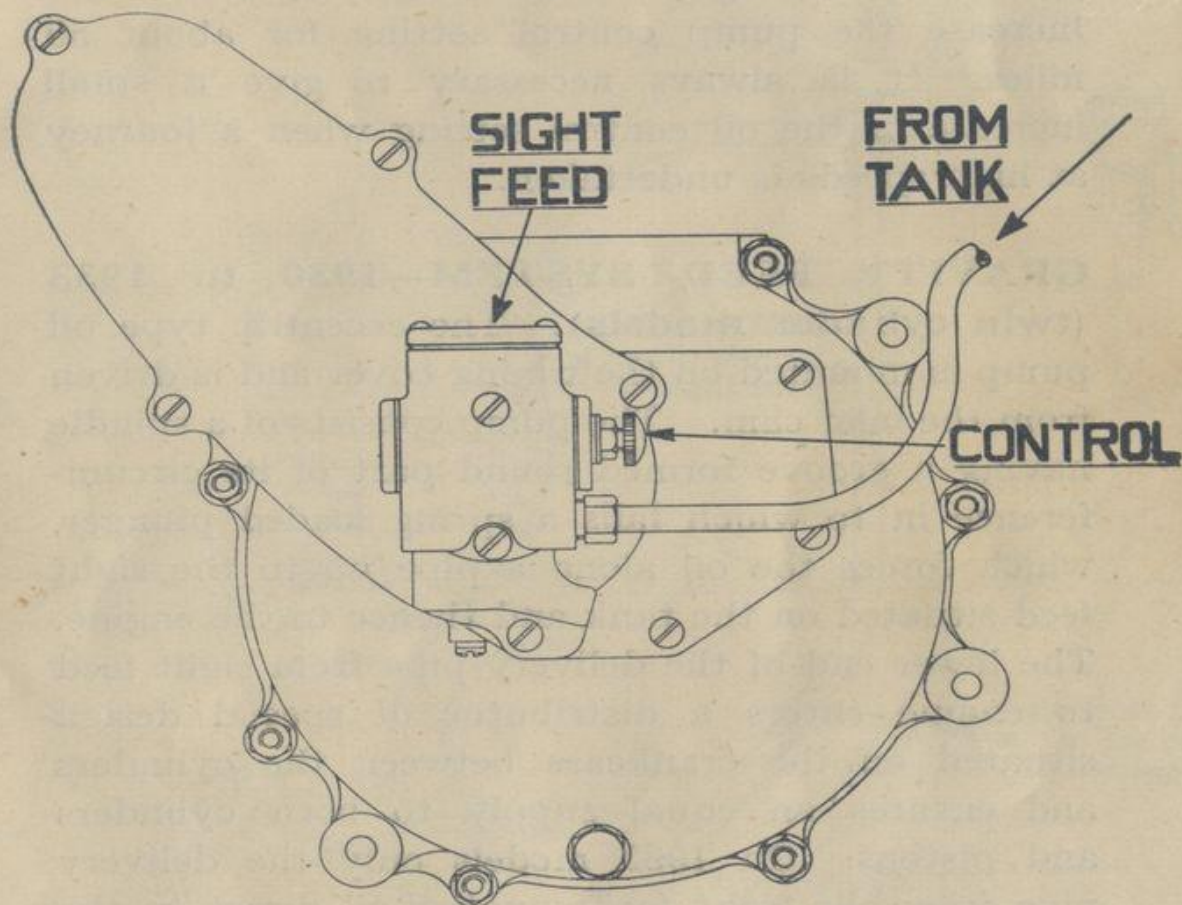

Fig. 3.

GRAVITY FEED SYSTEM—1933 to 1936 (except twin cylinder models)—(Fig. 3). Oil is drawn from a compartment in the petrol tank and delivered to the engine by a "Pilgrim" oil pump (see note on pilgrim oil pump, page 14), mounted

on the timing cover. A sight feed is incorporated so that the supply of oil can be readily checked and should be adjusted so that there is just a puff of bluish smoke from the exhaust when the throttle is opened suddenly after the engine has been running slowly for a while.

Beyond seeing that there is oil in the tank, and taking care to drain the crankcase every 1,000 miles, little attention is required. After draining give the cylinder a charge of oil (about two teaspoonsful) through the sparking plug hole, and increase the pump control setting for about 50 miles. It is always necessary to give a small increase in the oil control setting when a journey at high speeds is undertaken.

GRAVITY FEED SYSTEM—1930 to 1933 (twin cylinder models). The eccentric type oil pump is mounted on the timing cover and is driven from the inlet cam. The pump consists of a spindle having a groove formed round part of its circumference in to which falls a spring loaded plunger, which forces the oil along a pipe up to the sight feed situated on the tank and thence to the engine. The lower end of the delivery pipe from sight feed to engine enters a distributor of special design situated on the crankcase between the cylinders and ensures an equal supply to both cylinders and pistons. On 1933 models only the delivery pipe from the sight feed supplies oil direct to the big-end as shown in Fig. 4.

The supply of oil passing through the sight feed is controlled by an adjustable valve, which should be set to pass a steady succession of drops of oil, sufficient to cause a puff of bluish smoke from the exhaust when the throttle is opened suddenly after the engine has been running slowly for a while.

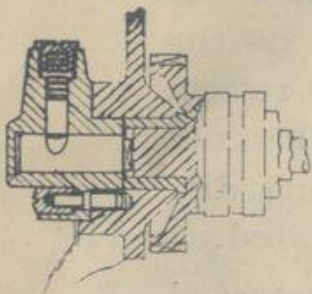

Section showing pump drive

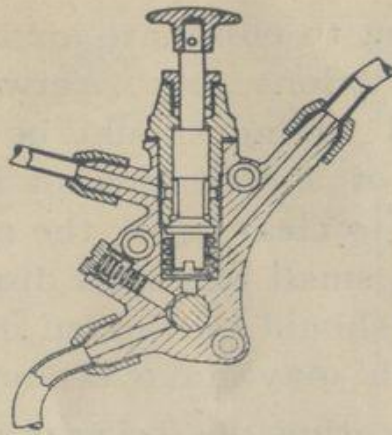

Section of pump and chain oiler

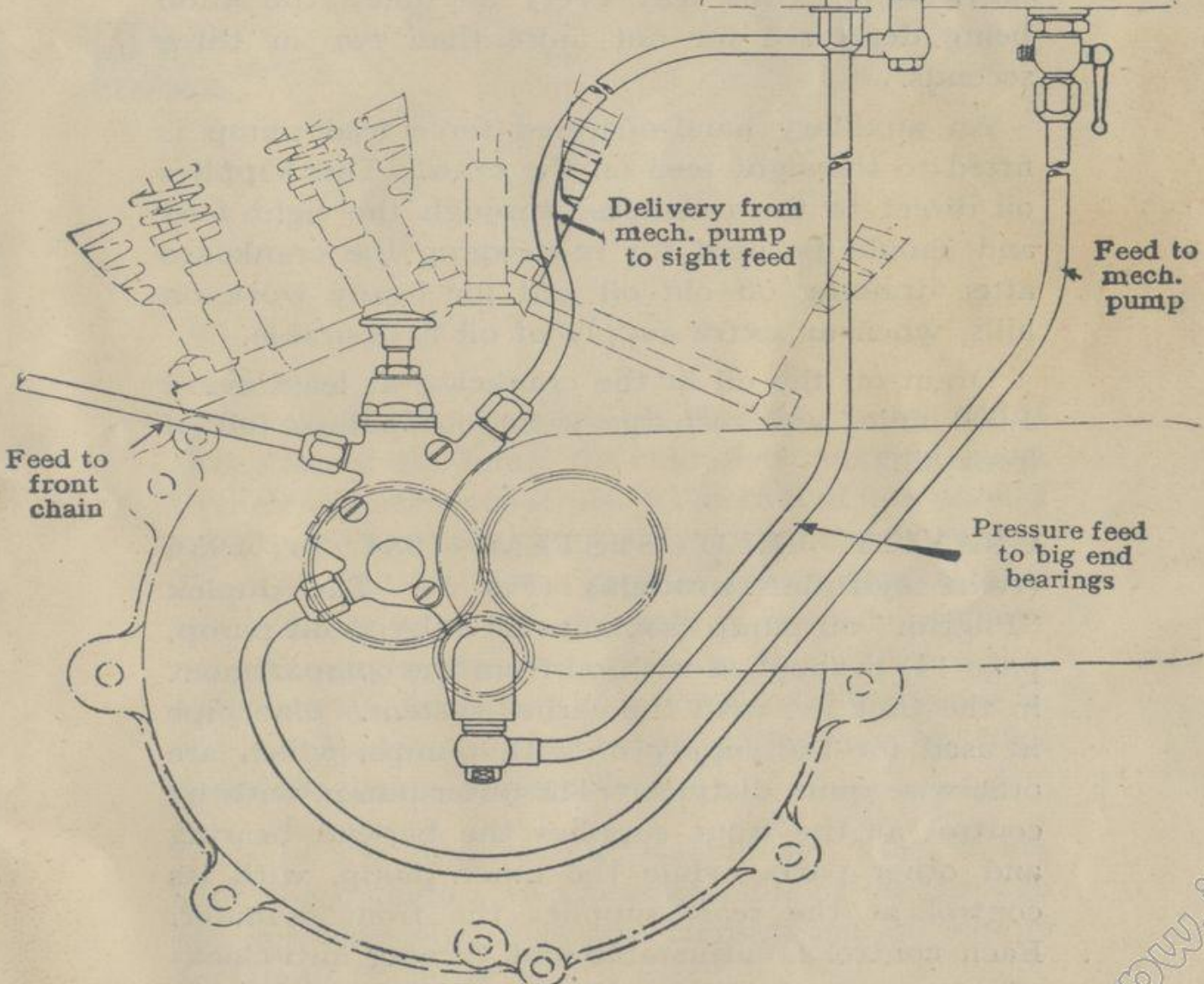
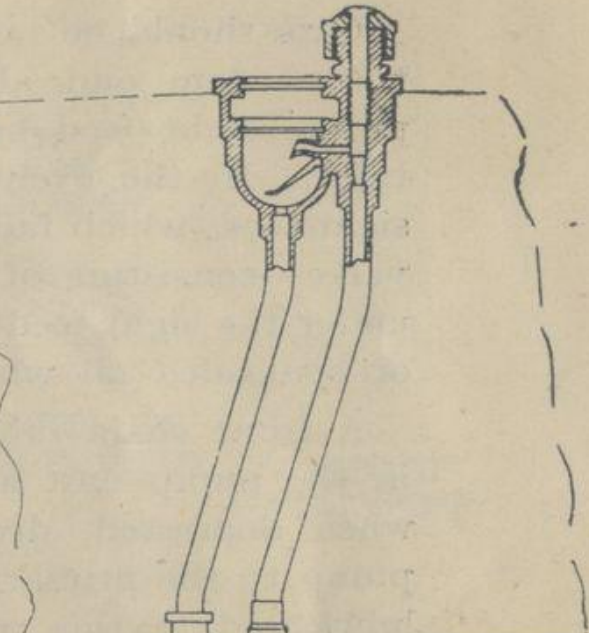

Fig. 4.

Care should be taken to eliminate air leaks from this system and all unions, etc., between tank, pump, sight feed and engine should be quite air tight. In the event of a collection of oil in the sight feed, which fails to clear itself, the non-return valve—consisting of a small pen-steel disc situated under the sight feed—should be cleared of any dirt or congealed oil which may have accumulated.

A front chain lubricating device is incorporated in the pump unit and consists of a knob, which, when depressed, diverts the oil supply from the pump to the primary chain. The latter should be lubricated in this way every 50 miles, the knob being depressed for not more than two or three seconds.

An auxiliary hand-operated force feed pump is fitted to the sight feed on the tank. This supplies oil direct to the crankcase through the sight feed and should be used for re-charging the crankcase after draining off old oil and for heavy work on hills, when an extra supply of oil is desirable.

Drain-off the oil in the crankcase at least every 1,000 miles and recharge with four pumps full of fresh oil.

GRAVITY FEED SYSTEM—1934 to 1936 (twin cylinder models) (Fig 5). The duplex "Pilgrim" oil pump (see note on Pilgrim oil pump, page 14) is supplied with oil from the compartment in the tank, as with the earlier system. One pipe is used for the supply of both pumps, which are otherwise quite distinct. The outer pump, with its control at the front supplies the big-end bearing and other parts, while the inner pump, with its control at the rear, supplies the front cylinder. Each control is adjustable and turning anti-clockwise increases the flow. The oil can be seen flowing

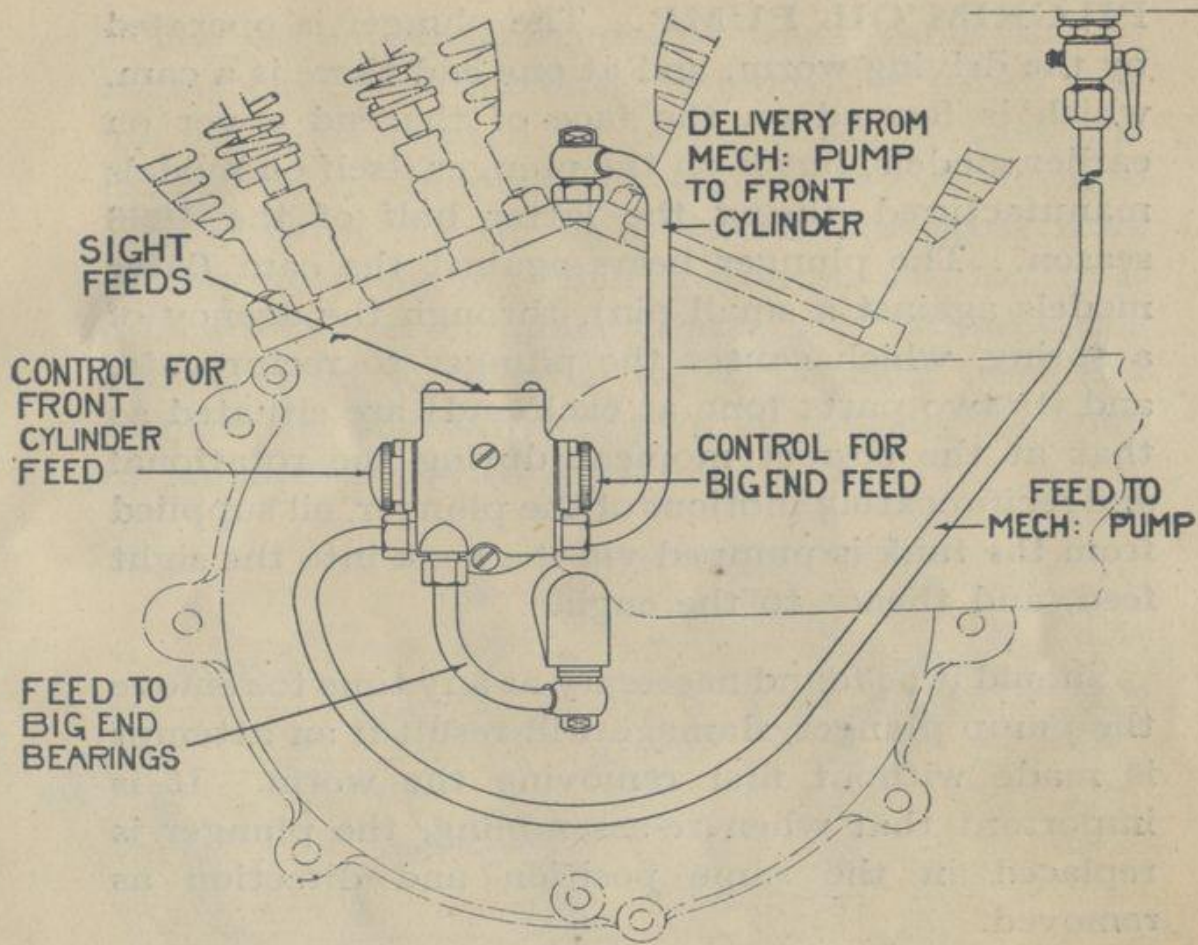

Fig. 5.

in the small chambers visible through the openings at the top of the pump, the chambers being adjacent to their respective controls. The rate of flow should be adjusted to suit the general conditions of use. There should be just a puff of bluish smoke from the exhaust when the throttle is opened suddenly after the engine has been running slowly for a while. It is always necessary to give a small increase in the oil control setting when a journey at high speeds is being undertaken.

Drain the crankcase at least every 1,000 miles, give the cylinders two teaspoonsful of oil through the sparking plug hole and increase the oil supply for about 50 miles.

PILGRIM OIL PUMP. The plunger is operated by the driving worm, and at one end there is a cam, which is formed on the face of the end cover on earlier models, but is on the plunger itself on models manufactured during the latter half of the 1936 season. The plunger bears against the cam (later models against a small pin), through the agency of a spring, which causes the plunger to reciprocate, and its two parts (one at each end) are situated so that at the correct moment during the rotational and reciprocating motions of the plunger, oil supplied from the tank is pumped via the beak into the sight feed, and thence to the engine.

Should it be found necessary at any time to remove the pump plunger, damage will result if an attempt is made without first removing the worm. It is important that when re-assembling, the plunger is replaced in the same position and direction as removed.

It is essential that all joints in the pump are air tight and that the joint between pump and engine is made oiltight by means of a paper washer, care being taken to ensure that the oil hole between pump and engine is kept clear. The latter instruction will not, of course, apply to the duplex type of pump, but the foregoing description applies equally well to both types of pump.

“DRY SUMP” SYSTEM (Fig. 6). The oil container is separate and the gear type pump is driven from the timing side mainshaft by worm gearing.

The oil which drains to the bottom of the crankcase is picked up by the flywheels and returned to a reservoir at the rear of the crankcase by the action of a scraper on the rims of these.

The oil supply is regulated by a valve on the timing cover (except on 1936 models in which case no valve is fitted). It is so arranged that the extension on the control knob, by coming into contact with the timing cover, is prevented from unduly rotating in either direction, so that it is difficult to over or under lubricate. Normally this control is set so that the valve is opened from half to just over one complete turn by rotating the knob in an anti-clockwise direction.

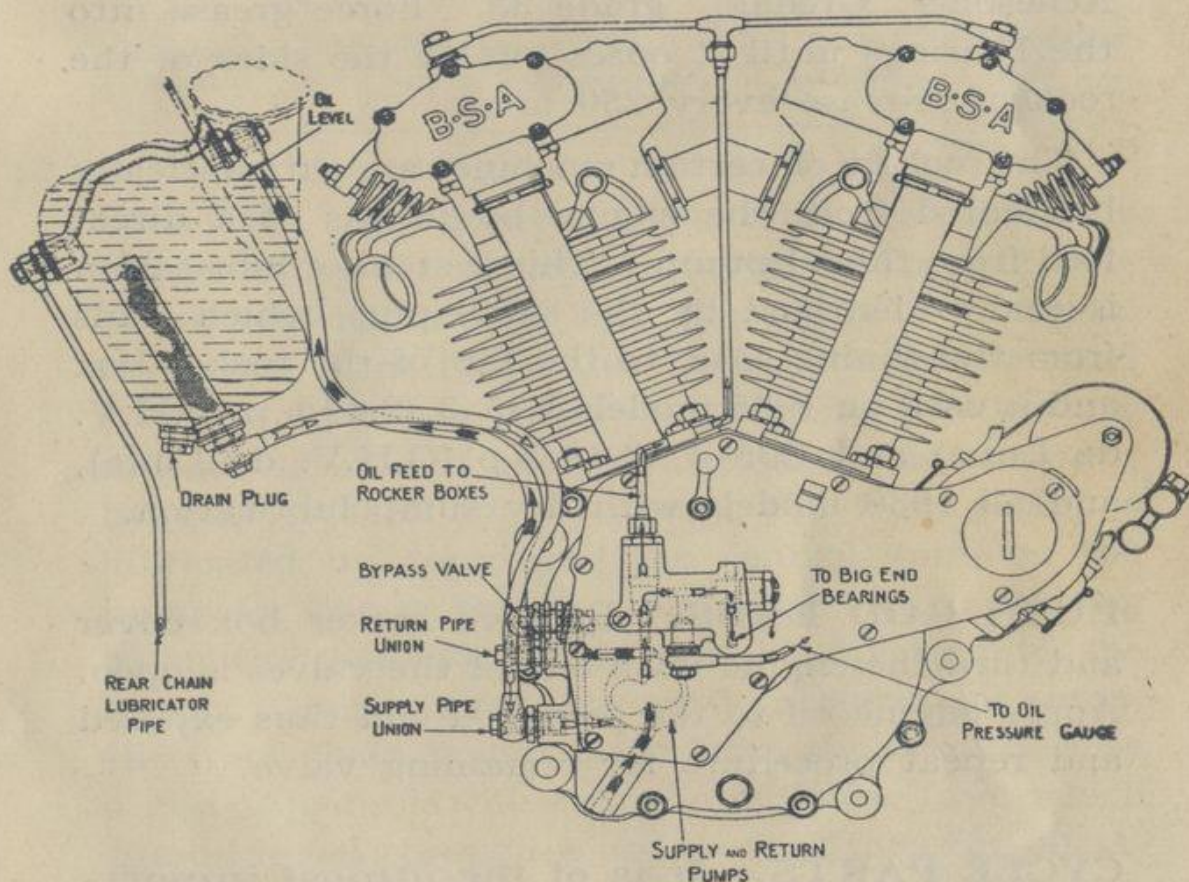

Fig. 6.

The oil flow is indicated either by a tell-tale on the timing cover, which should project about a quarter-of-an-inch when the oil is circulating or by an oil pressure gauge in the tank, the normal readings on which should be 8-15 lbs. per square inch when cold, and 3-9 lbs. per square inch when warm.

If the tell-tale moves in and out continuously instead of remaining stationary, or if the oil gauge reading falls much below normal, it is essential that the oiling system be checked over, first ascertaining that the sump contains oil.

ROCKERS. Grease gun nipples are fitted to the overhead rocker spindles and lubrication of these points should be carried out regularly. Use a high meltingpoint graphite-impregnated grease, such as Acheson's "Gredag," grade 33. Force grease into the bearings until it oozes out at the sides of the rocker. Grease every 250 miles.

The rockers on certain machines are automatically lubricated from the engine by means of a direct feed from the oil pump. This system of lubrication is easily identified by the small pipe, which leads from the timing case, to the top of the rocker box and is used on 1935 models B35-3 (2.49 h.p. O.H.V. de Luxe) and B35-4 (3.48 h.p. O.H.V. de Luxe), and all 1936 models with dry sump lubrication.

PUSH ROD ENDS. Remove rocker box cover and turn the engine until one of the valves is open. Apply engine oil to the push rod end thus exposed and repeat procedure for remaining valve.

CYCLE PARTS. It is of the utmost importance that the hubs and steering head should be greased every 500 miles. The brake cams should be greased every 1,000 miles, but avoid over lubrication of these parts together with the hubs, since any excess of grease may reach the brake linings and impair their efficiency.

The front fork links should be greased every 250 miles, while the foot gear change (if fitted) and the

clutch operation (on later models only) should be greased every 1,000 miles.

A few drops of oil should be given to the control levers, exposed cables, brake rod joints and gear change (hand operated).

For correct lubrication we recommend the high quality greases tabulated below.

Wakefield	Vacuum	Shell	Essolube	Price's
Castrolase Heavy	Mobilgrease No. 2	Shell Retinax	Esso Grease	Belmoline D

CHAINS. The front chain is lubricated from the crankcase by an adjustable valve on the left side, on models with "sump" and "dry sump" lubrication. Oil is fed from this valve through a hollow stud into the chaincase, where a trough is provided to collect the oil. If the lubrication of the engine is by gravity feed to the pump, the front chain is lubricated by depressing the control knob on the pump for two or three seconds with engine running when the engine's supply will be diverted to the chain. On machines fitted with a Pilgrim oil pump, the front chain is lubricated from the crankcase by a non-adjustable valve on the left side, from which the oil is fed through a hollow stud into the chaincase.

It is advisable to remove the chains periodically, and thoroughly lubricate them. Clean them in petrol or paraffin, allow to dry and warm them gently in a mixture of grease and graphite. When cool, wipe off the excess lubricant and replace the chains. **Make sure that the open end of the spring fastener is at the rear of direction of travel of chain.**

GEARBOX. To fill the gearbox with oil, remove the filler plug, which will be found either at the rear on the right hand side or at the front on the top. If the gearbox is of the type that is fixed with a bolt above and below, there will also be an oil level plug in the gearbox end plate on the right, which should also be removed.

Pour oil into the gearbox until it overflows from the level plug and on models not fitted with a level plug, fill with oil to the level of the spout. When filling, work the kickstarter once or twice in order to remove any air bubbles, and do not forget to replace all plugs before running.

Inspect the oil level every 500 miles and after every 2,000 miles drain and flush the gearbox with paraffin, and refill with engine oil. Should leakage occur due to wear, etc., use heavy gear oil.

RUNNING ADJUSTMENTS.

TAPPET CLEARANCES. Particular attention should be paid to the valve clearances, the settings of which should be checked periodically and are given on pages 45-48. Set the piston at the top of the compression stroke. This can be checked by removing the sparking plug and feeling the position of the piston while rotating the engine a little in either direction. This can be done when the machine is on the stand, by engaging a gear and turning the back wheel. Note that when the piston is at the top, the valves are closed, and neither one nor the other is opened by a movement backwards or forwards. Always check the clearances with the engine cold.



Fig. 7.

On Side Valve Models remove the valve cover and with a spanner on *A* (Fig. 7) hold the tappet head and release locknut *B* with another spanner by turning clockwise. Then hold the tappet stem by means of a spanner on the flats at *C* and obtain the required clearance by screwing head *A* up or down. Now lock *B* against *A* and again check clearance. Replace the valve cover.

On O.H.V. Models remove the rocker box cover by releasing the spring clips. On certain 1935 and 1936 models the inlet valve rocker

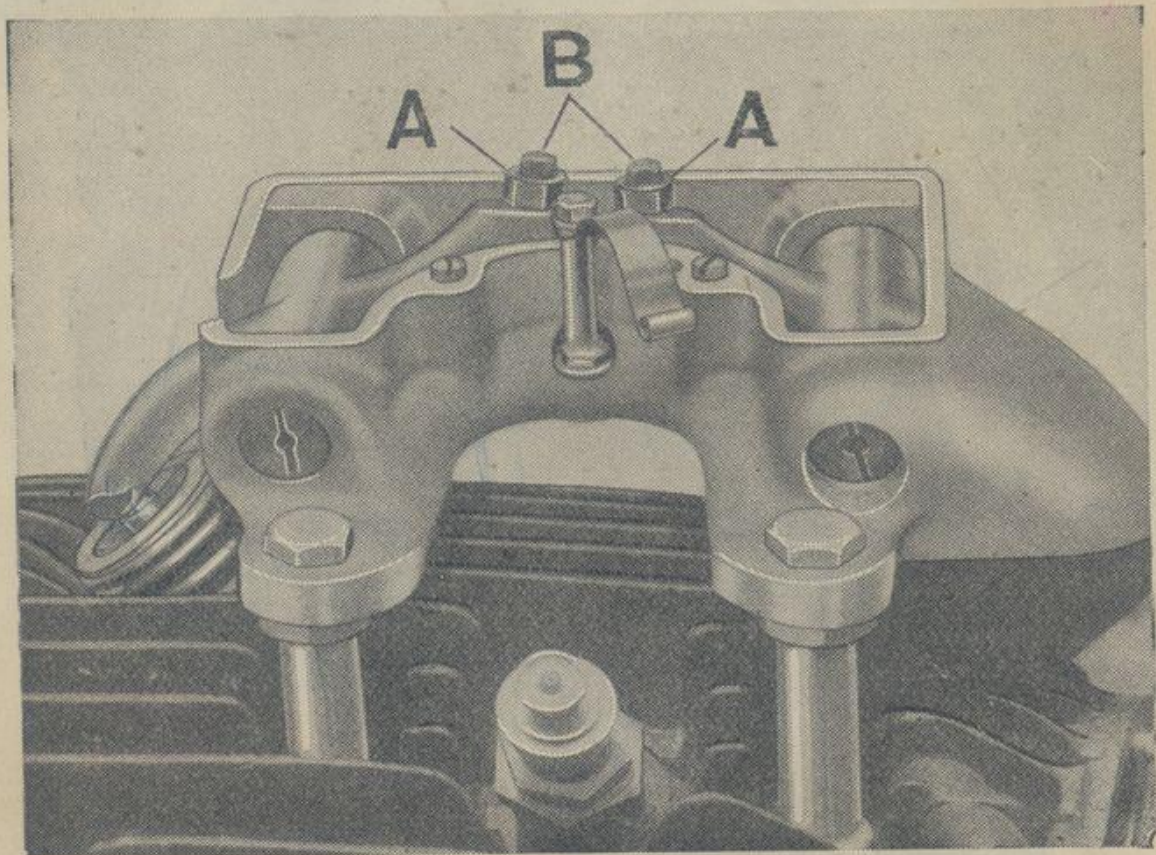

Fig. 8.

only is enclosed and the cover is taken off by removing the two fixing screws. Undo the locknut *A* (see Figs. 8 and 9) and turn the square end of the

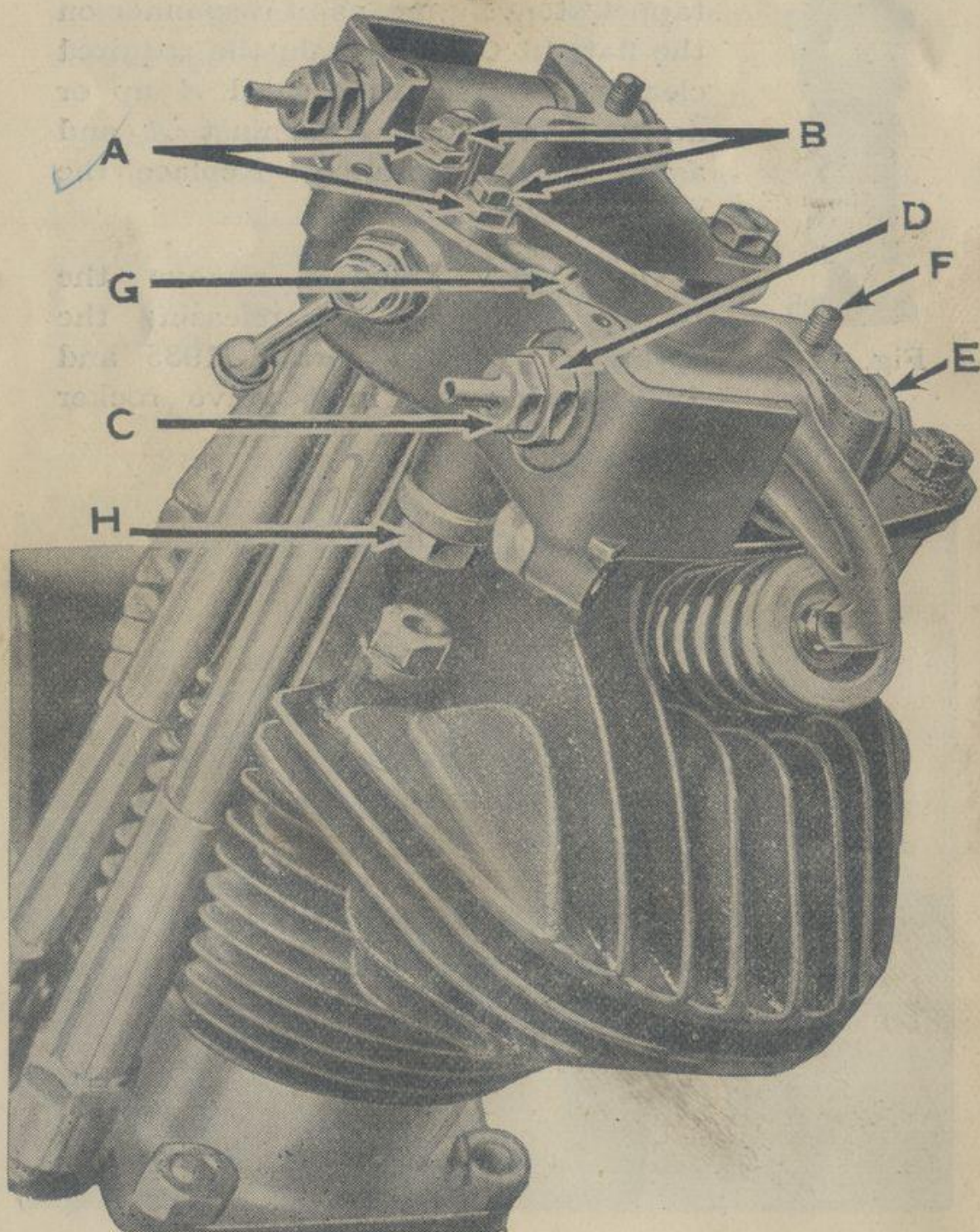

Fig. 9.

screw *B* until the correct clearance is obtained. Tighten the locknut and check the clearance again. Replace the rocker box cover.

ADJUSTMENT OF ROCKERS (Fig. 9). Release locknut *C* and turn the adjusting nut *D* in a clockwise direction until it just becomes tight. Slacken back about one-third of a turn and tighten locknut *C*. Hexagon *E* should not be touched unless it is desired to remove rocker spindle when locking stud *F* must also be released.

BRAKES. A wing nut at the rear end of the brake rod effects the rear brake adjustment. The front brake is adjusted by a screwed sleeve nut on the cable stop, mounted on the front forks. Tighten the knurled locknut after adjustment.

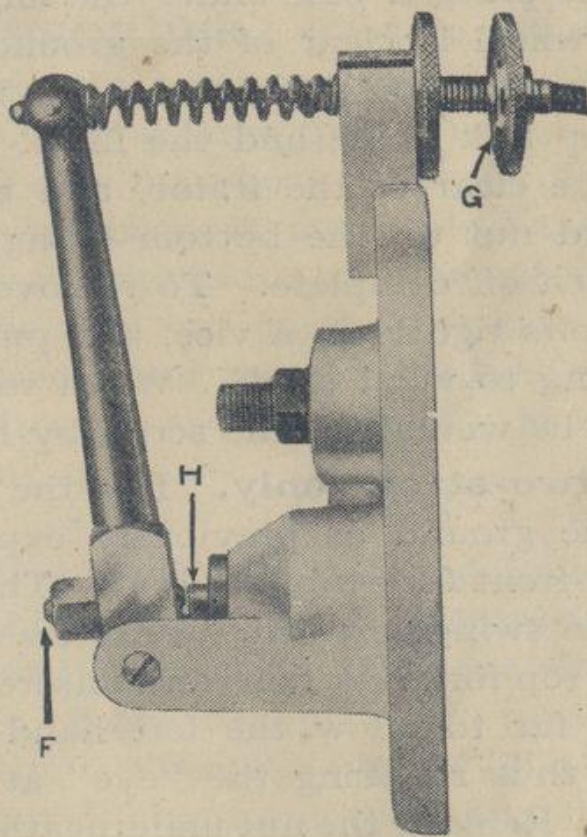

Fig. 10.

CLUTCH OPERATION. The adjustment should be set so that there is a little free movement between screw *F* and rod *H* (Fig. 10). If this is not so adjust the central screw *F*, having first released the lock-nut, and use the knurled thumb nut *G*, as a final adjustment only. The ball thrust should be lubricated regularly; in the case of the exposed operation type, oil every 250 miles, but the totally enclosed type should be greased about every 500 miles.

FRONT FORKS. Keep the link bolts just tight enough to eliminate side play. To adjust, release the nuts on the left-hand side, screw up the bolts on the right-hand side, and re-tighten the nuts. It is better to release the shock absorber before adjusting the links.

FRONT FORK SPRING. To replace the fork spring, first place a box under the engine so that the front wheel is clear of the ground. Take off the nut from the top spring retaining bolt, remove the two top link bolts, and the links. The spring will then be clear of the frame, and by removing the pin and nut on the bottom fixing, the spring can be taken off complete. To remove the scrolls, hold the bolts tightly in a vice, and punch the end of the spring to wind it off. When replacing, the spring can be wound on the scroll by hand.

1.74 h.p. two-stroke only. Lift the front wheel clear of the ground as previously explained, and remove the front fork top link bolt. This will allow the forks to swing forward. Unscrew the locknut on the rear top fork link bolt, and unscrew the latter sufficiently far to allow the left hand link to be swung up, thus releasing the "eye" at the top of the spring. Remove the nut underneath the bottom spring bracket and the spring can then be lifted out.

STEERING DAMPER. On all except the smallest models a B.S.A. steering damper is fitted to the lower end of the steering stem yoke, and the pressure is adjustable by means of a knob, mounted on the top of the steering head. The pressure should be increased with a sidecar combination, when it will eliminate the tendency to "handlebar wobble," and reduce steering drag, while with a solo machine it will ensure stability at high speeds on rough roads.

STEERING HEAD. To adjust the steering head place a box under the engine and take the steering damper knob off (if fitted). Loosen the clip and then gently tighten the top adjusting nut until there is no perceptible shake in the head. **If over adjusted the races will be damaged.** Tighten the clip nut and replace the damper knob.

SHOCK ABSORBER. To adjust the amount of friction it is only necessary to screw the wing nut (or in some cases a large thumb nut) to the left or right as the case may be. On some of the smaller models no provision is made for hand operation and on these machines the adjustment is as follows: Slack off the rear nut on the left side of the fork and then screw up or unscrew the bolt to give more or less friction as required, finally locking up the left-hand nut again.

HUB ADJUSTMENT—Ball and Roller (Fig. 11). The hubs should be tested frequently for side play and adjusted if necessary. Remove the wheel and then slacken off the locknut *A* and turn the bearing nut *B* gently. When the play is all taken up unscrew the nut *B* about one-third of a turn, or until play can just be felt when the spindle is rocked

sideways, and upon tightening the locknut *A* see that this play is not all taken up. The adjustment will be correct if there is **just perceptible side play in the bearing as measured at the wheel rim.** Do not screw the bearing nut *B* up too tight when making the preliminary adjustment or the

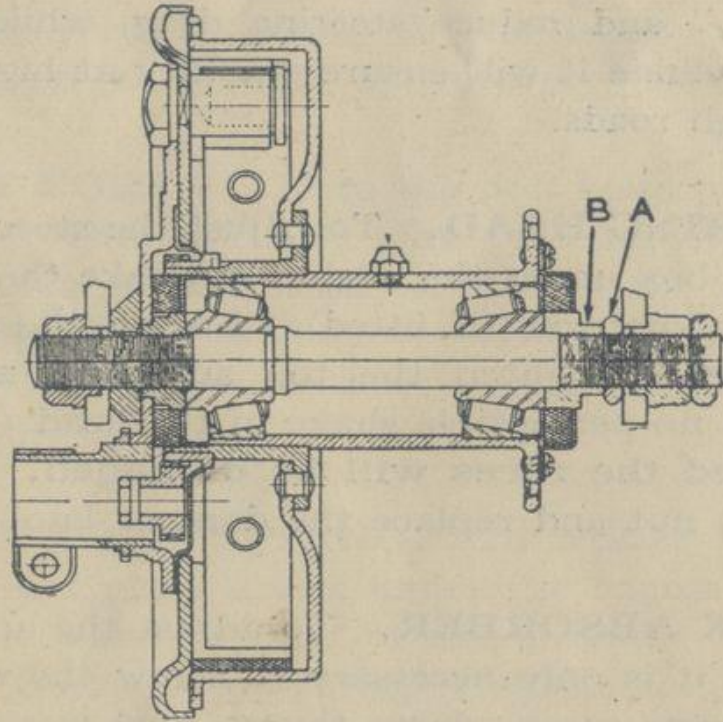

Fig. 11.

rollers and race may be damaged. The 1930 and 1931 models are not fitted with locknut *A* and adjustment is made direct with the bearing nut.

DETACHABLE REAR WHEELS. Three different types of quickly detachable rear wheels have been used on B.S.A. motor cycles and an inspection of the rear hub will show the rider which of the following types is fitted to his machine.

On all models fitted with quickly detachable rear wheels, the rear guard is hinged to facilitate removal of the wheel, the hinged portion being held by the

lower rear stays. Shouldered nuts are used on the studs attached to the mudguard at this point and it is important to locate these and the two registers in the lower rear stays correctly.

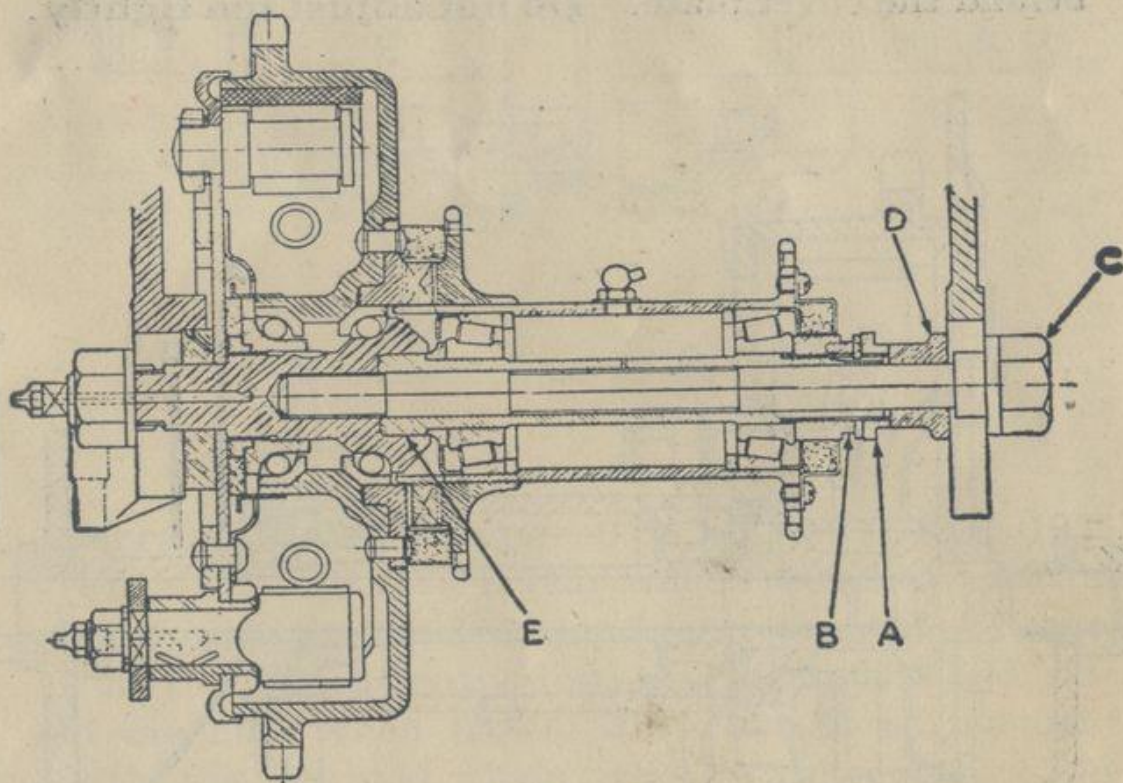

Fig. 12.

Dog Coupling Type (Fig. 12). To remove the wheel it is only necessary to unscrew the wheel bolt *C* on the right-hand side of the hub and draw this nearly out. Then, using the projecting bolt as a handle, slide it to the rear, carrying with it the distance piece *D*. When this is drawn clear, the wheel should be moved bodily to the right, until it clears the driving dogs and it can then be withdrawn to the rear. Adjustment of the wheel bearing is carried out in a manner similar to that described in the previous paragraph, except that while the adjustment is being made the hollow spindle must be held by a spanner on the flats *E*. The chain-

wheel bearing is adjusted when removed from the frame. A special tool in the kit is used to hold the centre portion to the dogs on the drum, while the adjusting cone is turned to a suitable position after releasing the locknut, which is situated immediately behind the cover plate. **Do not adjust too tightly.**

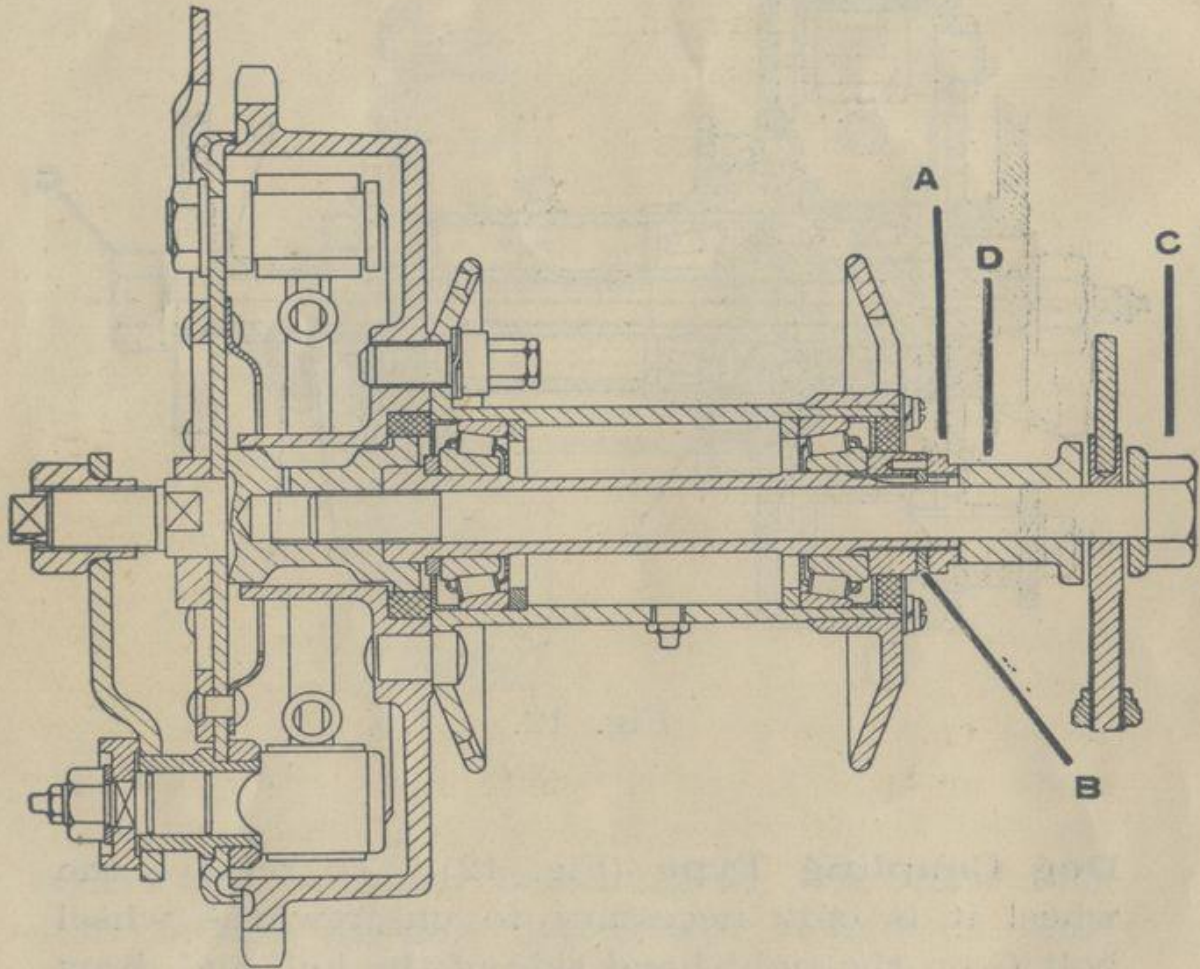

Fig. 13.

Three Peg Coupling Type (Fig. 13). To remove the wheel, first detach the three retaining bolts round the hub centre. Then remove spindle *C* and distance piece *D*, and withdraw the hub to the right from the pegs. The wheel can then be taken out rearwards. Adjustment of the wheel bearing is carried out as above.

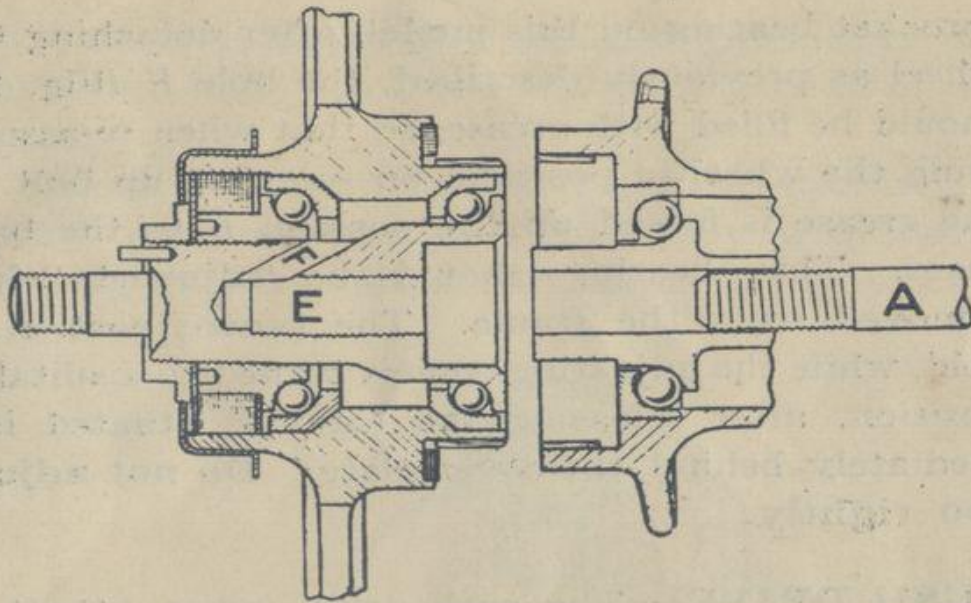

Fig. 14.

Serrated Centre Type—9.86 h.p. only, 1931–1935 (Fig. 14). To detach rear wheel, withdraw central bolt from right-hand side and remove packing sleeve. Pull the wheel gently towards the right-hand side of machine when it will drop out of engagement with the serrated chain wheel. In replacing the wheel thoroughly clean the serration on both hub shell and chain wheel and well coat both with grease. To detach the front wheel, first disconnect the front brake rod fork end. Then unscrew the nut on the left-hand side of the hub bolt, preventing the latter from rotating by means of a spanner on the right-hand end. Pull out the bolt and the wheel will be free to drop out. Do not lose the distance piece which goes between the hub and the wheel bracket on the left-hand side. When replacing the front wheel, be sure that the brake cover plate stud engages with the slot on the inner side of the wheel bracket. Push the bolt partly through the hub, place the above-mentioned distance piece in position, then push the bolt right through and screw up the nut on the left-hand side. To lubricate the rear

sprocket bearing on this model, after detaching the wheel as previously described, the hole *E* (Fig. 14) should be filled with grease, so that when re-assembling the wheel in position, on screwing up bolt *A*, the grease is forced up the passage *F* to the ball-races. This bearing should be adjusted when removed from the frame. The centre portion is held, while the adjusting cone is turned to a suitable position, after releasing the locknut situated immediately behind the cover plate. **Do not adjust too tightly.**

CUSH DRIVE. The cush drive (when fitted) is mounted on the engine shaft and the spring tension can be adjusted by the two ring nuts, which hold the spring.

FRONT CHAIN. The chain tension should be inspected occasionally and on models with totally enclosed primary chains, an inspection cover is fitted on the chaincase for this purpose. To adjust the chain, the gearbox must be moved backwards or forwards, to tighten or loosen the chain as the case may be. If the gearbox bolts are both below the box, release them and move the gearbox by means of the screw adjuster (which will be found at the rear on the right-hand side) until the chain has half-an-inch movement up and down at the centre, for all positions of the sprockets. Make sure that the nuts are tight, after completing the adjustment. If the gearbox bolts are situated above and below the gearbox the screw adjuster will be found at the top of the box, on the right-hand side. The method of adjustment is the same as for the previous type of gearbox.

CLUTCH. All B.S.A. clutches are of the dry multi-plate type and occasionally should be dis-

mantled and thoroughly cleansed by means of a stiff brush and petrol, to remove all trace of oil and grease.

Should the clutch be found hard to operate, the spring pressure may be reduced by withdrawing the ring nut, but not to such an extent as to cause clutch slip.

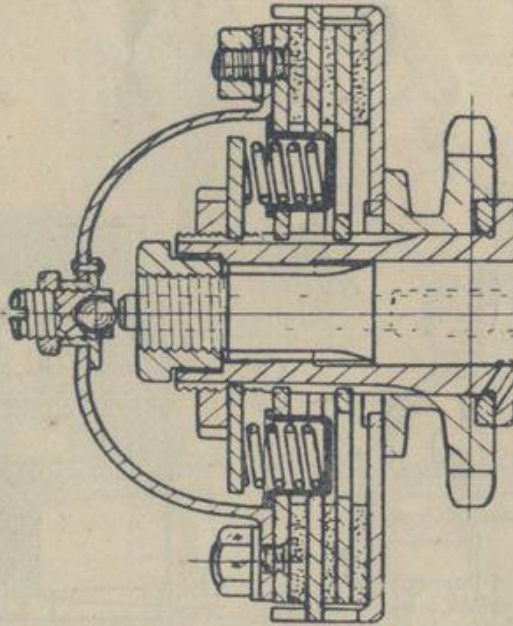
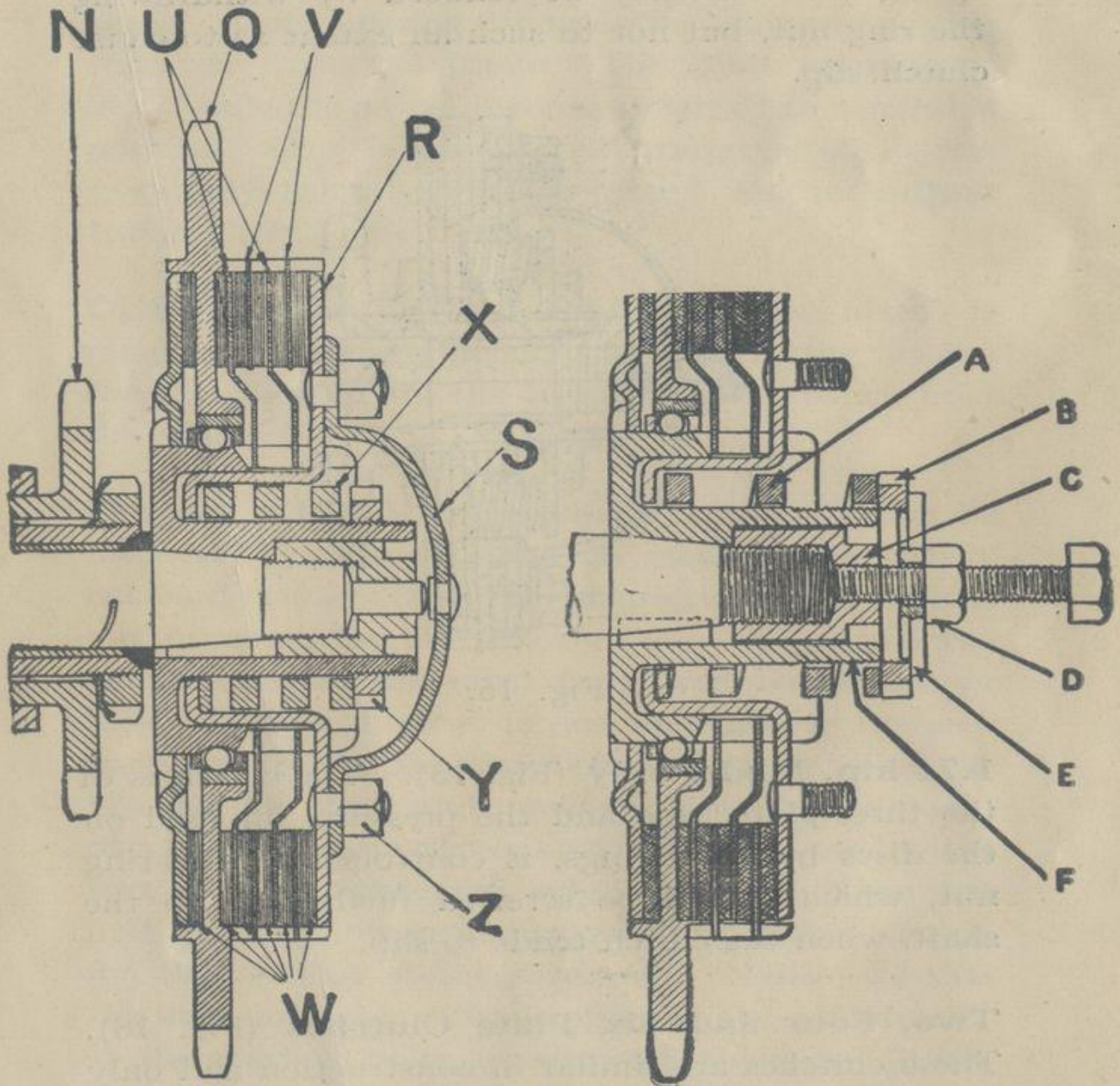

Fig. 15.

1.74 h.p. Model only (Fig. 15). The clutch is of the three-plate type and the pressure, imposed on the discs by six springs, is controlled by the ring nut, which should be screwed further on to the shaft, when the clutch tends to slip.

Two, Four and Six Plate Clutches (Fig. 16). These clutches are similar in construction and only differ in the number of plates and the method of applying pressure to the members. In the case of the two plate clutch, the pressure on these members is imposed by eight springs, the intensity being controlled by the centre ring nut, while on the four and six plate clutches the pressure is imposed by one large spring at the centre.

To dismantle, first unscrew the four nuts retaining the cover, remove the latter and then unscrew the ring nut. Note the order in which the steel plates



Figs. 16 and 16A.

are arranged so that they can be assembled in the same order. When re-assembling, the spring pressure has to be overcome before the central nut can be engaged on its thread. To enable this to be done, a thread $5/16$ dia. x 26 T.P.I. has been formed

in the small centre nut into which a setscrew (supplied in the tool kit) may be engaged when the clutch operating rod has been removed. It will be seen that by means of the nut *A* (Fig. 16A) and

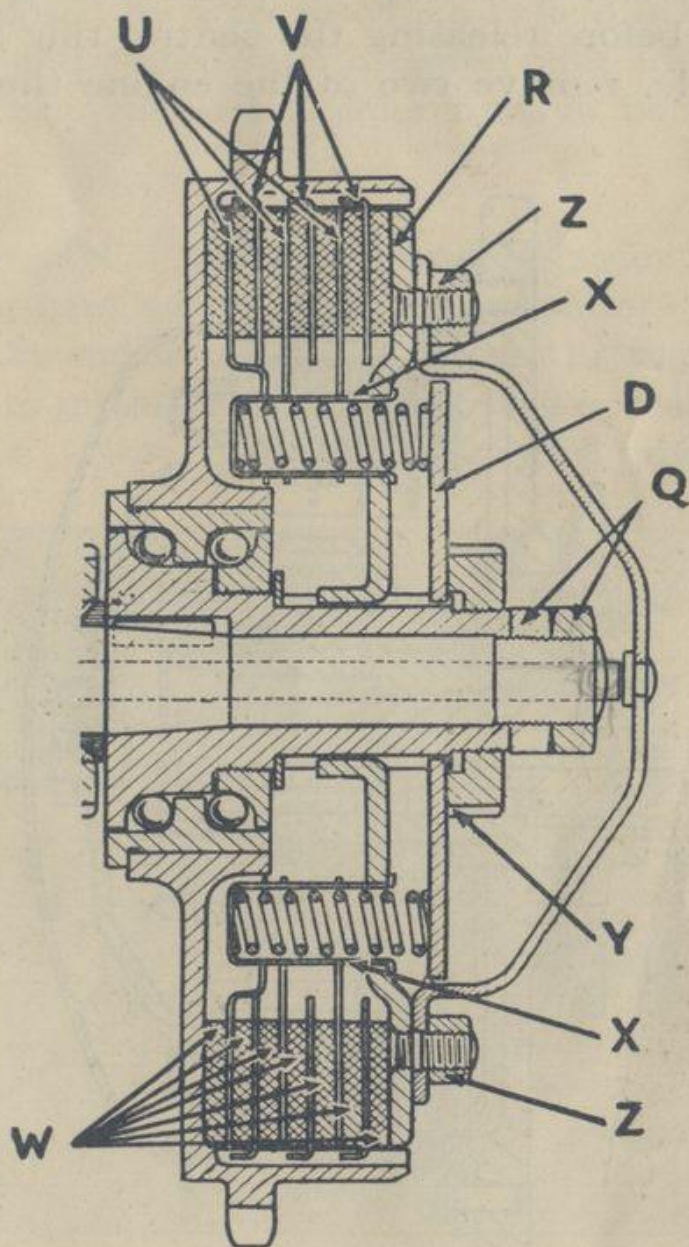

Fig. 17.

washer *B*, the nut *C* may be forced up the threaded portion *D* against the pressure of the springs *E*. When in this position, if the nuts *A* and *C* are now turned together, the latter nut will engage on its thread. Refit the cover and make sure that the nuts are tight.

Seven Plate Clutch (Fig. 17). Inspection of the diagrams will show that the clutch operates in a similar manner to the above, except that when dismantling after taking off the conical cap, there are two locknuts on the mainshaft which must be removed, before releasing the central ring nut. To re-assemble, remove two of the engine timing case

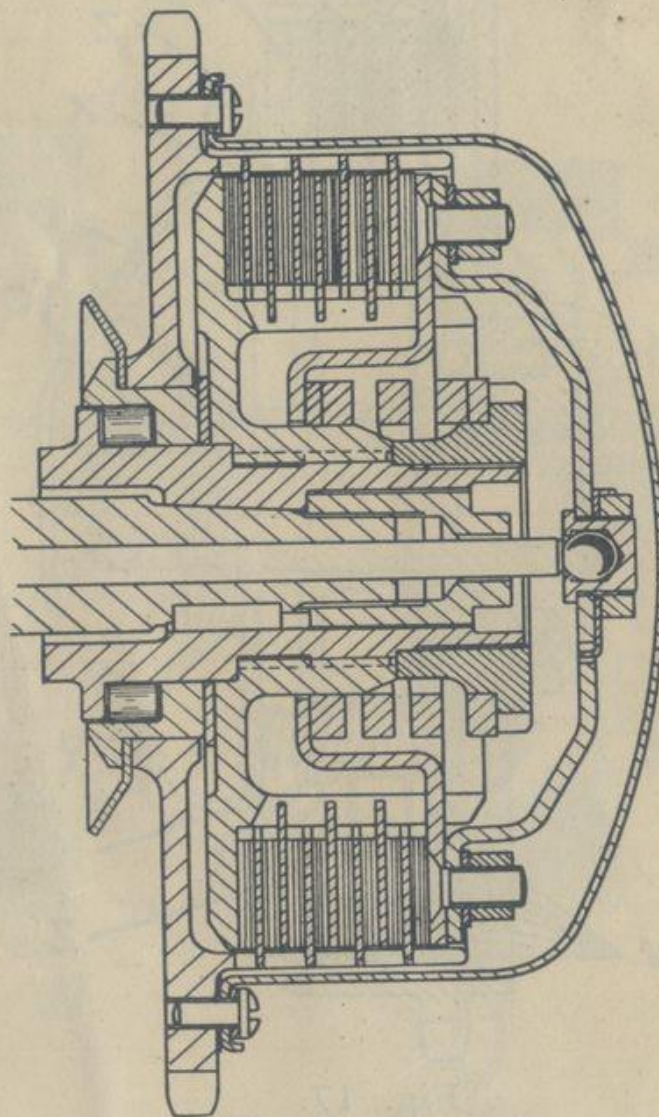

Fig. 18.

cover screws, thread these through the spring thrust plate, and screw into the clutch end plate, until the ring nut can be screwed on to the sleeve. When the end of the sleeve just protrudes through the

mainshaft, the locknuts can be replaced. Refit conical cap and make sure that the nuts are tight.

Eight Plate Clutch (Fig. 18). The clutch is similar to the six plate clutch, except that it is totally enclosed by a cover which is held in position by screws, and the spring pressure is not adjustable. The ring nut, therefore, must always be screwed up tight.

REAR CHAIN. The rear chain adjustment is by means of a cam on the rear hub spindle. Slacken off the brake rod flynut or uncouple the toggle end, according to model, and undo the brake cover plate anchor nut. Now release the spindle nuts, or in

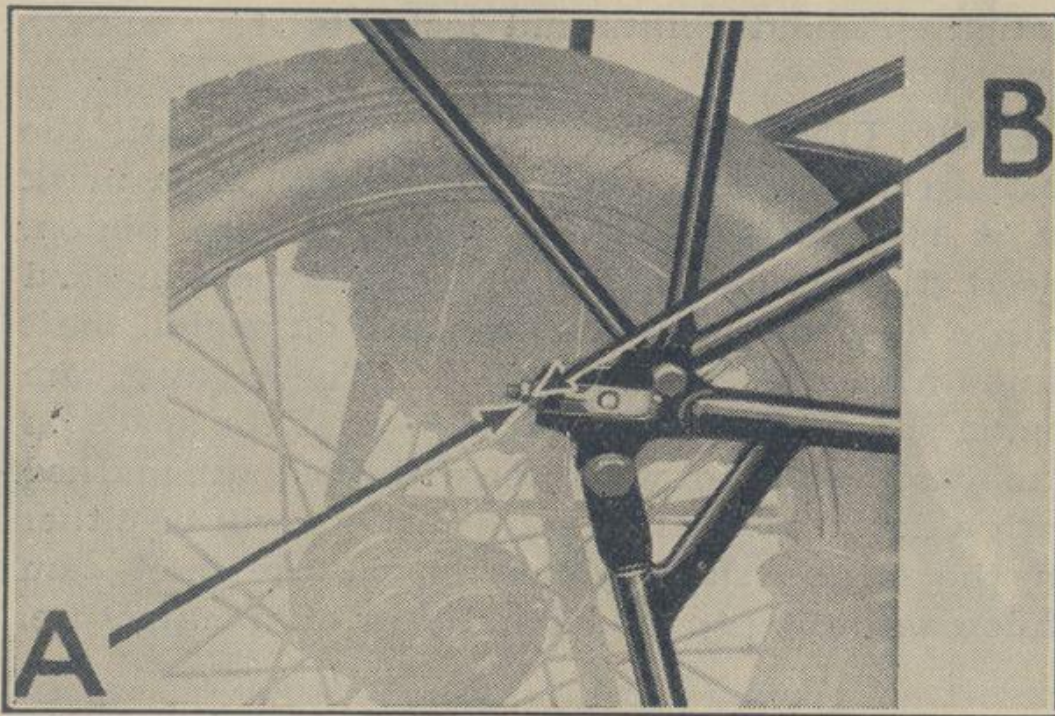

Fig. 19.

the case of models with detachable rear wheels, the knock out spindle. Rotate the hub spindle by means of a spanner on the small square on the left side, until the correct tension is obtained. The chain should have three-quarters of an inch freedom

at the centre. Make sure that this is correct for all positions of the sprockets and that the cam is against its stop. Tighten the left-hand spindle nut first and then the right-hand nut or knock out spindle. Fasten the brake cover plate anchor nut and replace the toggle end or screw up the flynut as the case may be. **Adjust the brakes to suit the new position of the rear wheel.**

9.86 h.p. (1930-1935). Slacken the hub spindle nut on each side of the wheel and release the locknuts *A* on the adjuster (Fig. 19). Turn nuts *B* alternately, one half turn at a time, until about half-an-inch sag can be felt in the chain through the inspection hole (rear chaincase models only). Retighten spindle nuts and locknuts *A*.

VALVE TIMING. Rotate the engine until the engine shaft pinion tooth with a small dash mark on it is pointing towards the inlet cam pinion. Insert the inlet cam pinion so that the space marked with a dash meshes with the tooth on engine shaft pinion also marked with a dash. The exhaust cam pinion should then be inserted so that the space on it marked with a dot will mesh with the tooth marked with a dot. This latter marked tooth will be either on the engine shaft pinion or on the inlet cam pinion according to model and year of manufacture.

MAGNETO TIMING. Release the magneto pinion and set the piston at top dead centre of the compression stroke. On 1930 to 1933 models inclusive, the ignition is timed in the fully retarded position (see pages 45 and 46). For 1934 models onwards proceed as follows. Rotate the engine backwards and measure the distance the piston descends from the top of its stroke. Set the contact breaker to

.002in. gap with the ignition control in the fully advanced position and re-tighten the magneto pinion. The correct distances of piston travel from T.D.C. for the various models are shown on page 45.

MAGNETO OR MAGLITA CHAIN Remove the chain cover plate and release the nuts at the side of the magneto base plate. Move the unit until the play in the chain is not more than one-eighth of an inch. Check this dimension after tightening the base plate nuts and for all positions of the sprockets.

GEARBOX.

All B.S.A. gearboxes are of the constant mesh type and gear changes are effected by means of sliding dogs operated by forks on a separate control shaft. The selection mechanism is located by a spring loaded plunger inside the box.

FOOT GEAR CHANGE—separate unit type (Fig. 20).—The only attention apart from lubrication, likely to be required is the replacement of a broken spring. Remove nut *S*, take off the large washer behind it and replace the nut to hold the mechanism together while removing the pedal. Draw off pedal *A* using an extractor screw in the tapped hole in the pedal and remove the screws holding cover *T* in position thus exposing the springs. Remove broken springs and fit new spring with the aid of a pair of pliers. To dismantle the mechanism completely proceed as above and having taken off springs and screw *U*, withdraw the remaining parts from the fixed shaft cover, taking care not to lose the plunger and spring at *O*. When

assembling first replace ratchet plate *F* and each of pawl arms in turn and make certain that the pawls are in line with the ratchet plate. Place the

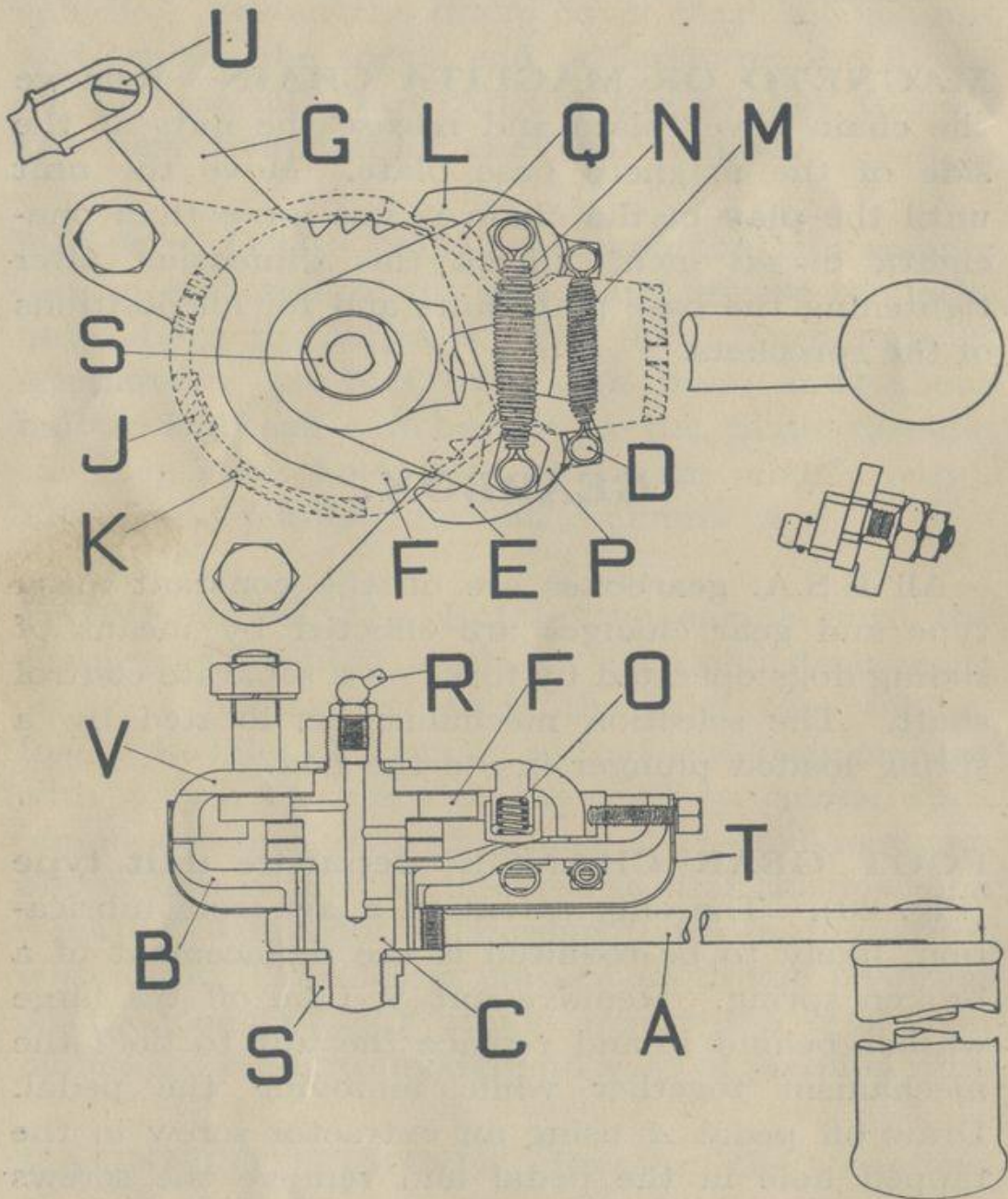

Fig. 20.

spring loaded plunger *O* in its socket and slide the operating plate over the shaft. Replace springs *M* and *N* as described above and refit cover, pedal, washer and nut.

FOOT GEARCHANGE—enclosed in gearbox (Fig. 21). In general the previous instructions apply to this type except in the following particulars.

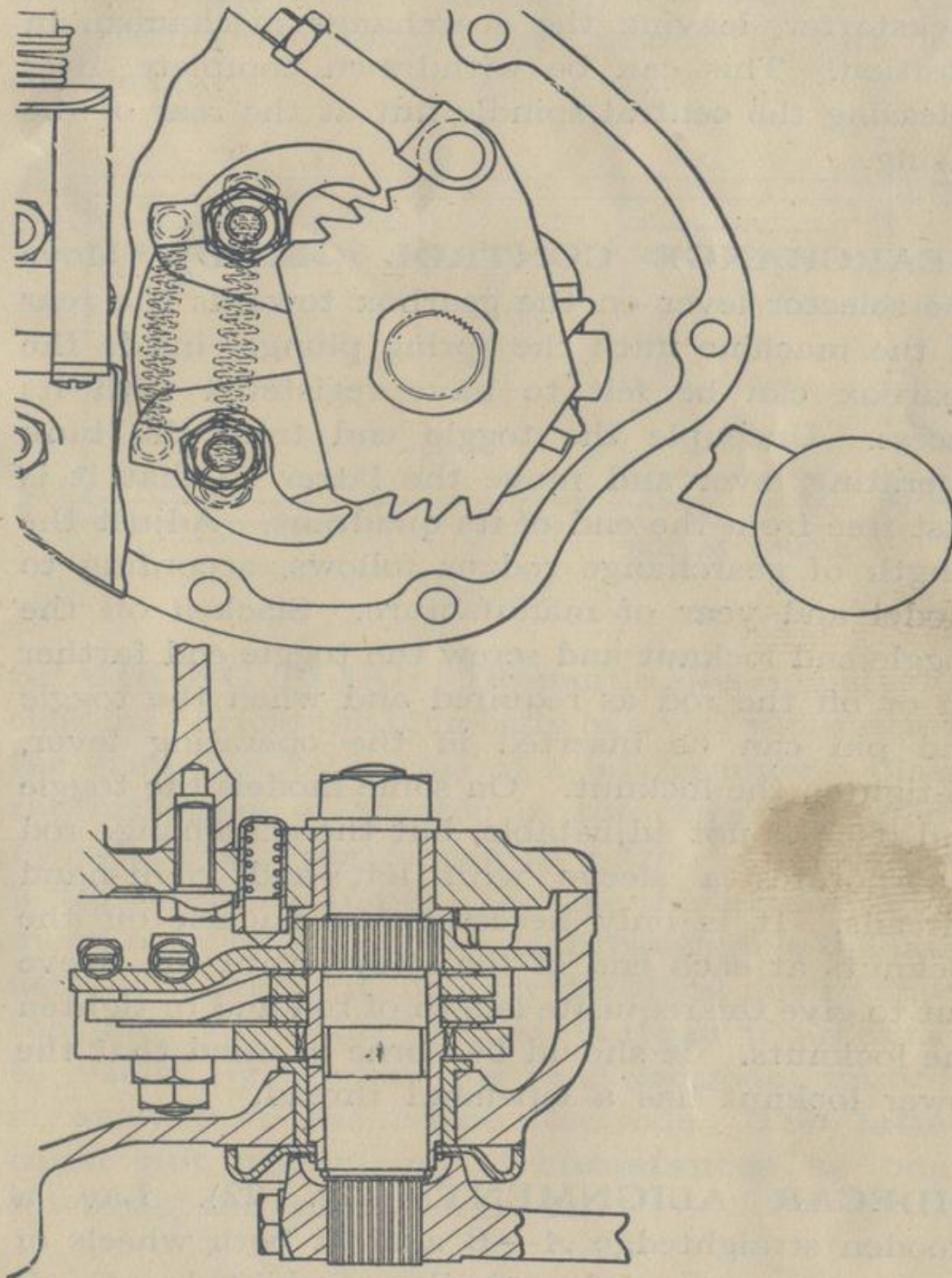

Fig. 21.

In order to remove the gearchange mechanism it is necessary to remove first the gear pedal (attached

by splines and pinch bolt) and then the circlip. Detach the clutch operating cable, and undo the gearbox cover nuts four of which are at the back of the casing. Remove the cover complete with kickstarter, leaving the gearchange mechanism in position. This can be withdrawn complete after releasing the central spindle nut at the rear of the casing.

GEARCHANGE CONTROL (HAND). Move the selector lever on the gearbox towards the rear of the machine until the spring plunger inside the gearbox can be felt to have registered with its recess. Uncouple the toggle end from the tank operating lever and move the latter so that it is just free from the end of its quadrant. Adjust the length of gearchange rod as follows, according to model and year of manufacture. Slacken off the toggle end locknut and screw the toggle end farther on or off the rod as required and when the toggle end pin can be inserted in the operating lever, re-tighten the locknut. On some models the toggle end itself is not adjustable, but the gearchange rod incorporates a sleeve with left and right-hand threads. It is only necessary to slacken off the locknuts at each end of the sleeve, turn the sleeve nut to give the requisite length of rod and re-tighten the locknuts. It should be borne in mind that the lower locknut has a left-hand thread.

SIDECAR ALIGNMENT (Fig. 22). Lay a wooden straightedge *A—B* against both wheels of the motor cycle and a similar straightedge *C—D* against the sidecar wheel. Make certain that the machine is upright or leaning outwards slightly by adjustment of the seat pillar connection and then adjust the sidecar until points *A* and *C* are half-

an-inch closer together than points *B* and *D*. After tightening up the rear connection to the chainstay slacken back the nut by half a turn before fitting its split pin to enable the ball joint to work. The ball connection should be lubricated with oil occasionally.

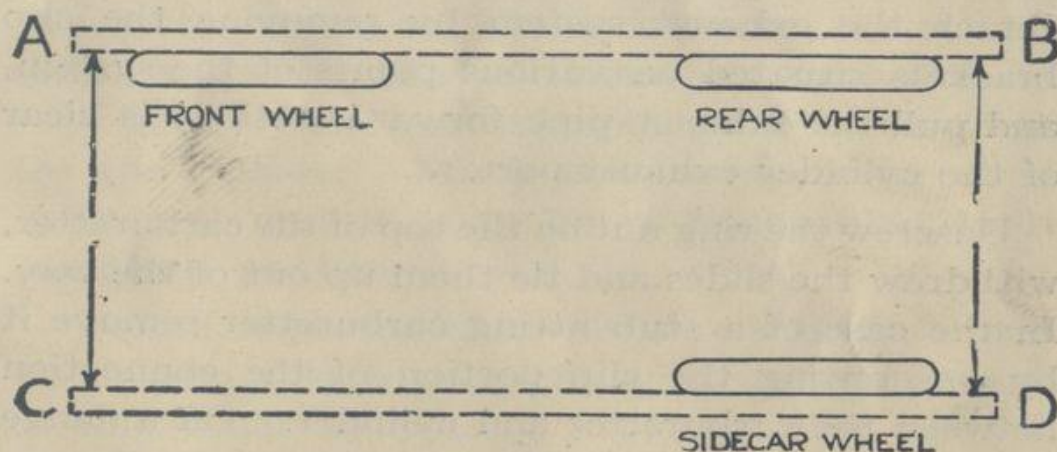

Fig. 22.

SPARKING PLUG. Dismantle occasionally for cleaning. Hold the plug body in a vice and unscrew the gland nut by means of a box spanner. Clean the insulation at the top of the central electrode by means of a rag dipped in petrol. **Do not use a file or emery paper.** Scrape the interior of the metal body clear of carbon and re-assemble the plug using only sufficient force on the gland nut to make the joint gas tight. Adjust the gap if necessary to .018in. by bending the side electrodes towards or away from the centre electrode. **The latter must not under any circumstances be bent towards the side electrodes.**

DECARBONISING THE ENGINE.

The need for this operation is a tendency to "pink" and a falling off in performance, and should be carried out as indicated.

Two-stroke Model. Every 1,000 miles.
Models up to 350 c.c. Every 2,000 miles.
Models from 500—1,000 c.c. Every 3,000 miles.

DISMANTLING. Remove the petrol pipe, sparking plug and exhaust valve lifter cable, or in the case of the 1.74 h.p. the decompressor cable. Now detach the exhaust system by removing the clip brackets situated on various points of the system, and pull the exhaust pipe forward until it is clear of the cylinder exhaust port.

Unscrew the ring nut on the top of the carburetter, withdraw the slides and tie them up out of the way. In the case of a stub fitting carburetter remove it by unscrewing the clip portion of the connection between the carburetter and cylinder. On a flange fitting carburetter undo the two nuts on the flange.

To remove the rocker box on O.H.V. models, unscrew the four attachment bolts, two of which are on the nearside and two on the offside. Now remove the push rod tubes, together with the push rods, by unscrewing the large nuts at the base of the tubes. Next, remove the cylinder head by unscrewing the two pillar nuts on the nearside and two nuts on the offside. Before removing the rocker box on the 595 c.c. O.H.V. it is necessary first to undo the lower push rod tubes, and lift the push rods off the tappets with a screwdriver. The push rods and tubes can then be removed complete. The head is held by five bolts threaded up through the cylinder barrel, and a special spanner is provided to undo these.

The 1932 4.99 h.p., 5.59 h.p. and 9.86 h.p. S.V. models and all S.V. machines manufactured after this year are fitted with detachable cylinder heads, and to remove them it is only necessary to undo the fixing bolts. It is not necessary to remove the

cylinder barrel on these machines or on the O.H.V. machines unless it is desired to inspect the piston rings, but with all other models remove the barrel by unscrewing the three or four nuts as the case may be which hold it to the crankcase. Lift the cylinder up and forwards into the front angle of the frame and then turn the engine forwards until the piston comes out of the bottom of the cylinder, steadying the piston as it emerges so that it does not fall over and get damaged when it comes clear of the cylinder. **Mark the inside front of the piston to enable it to be re-assembled in the original position.**

Before removing the valves on O.H.V. models, it is advisable to free the split cotters from the spring collar by placing a block under the valve head and striking the collar a sharp blow with a hammer. Insert the hook of the valve removal tool through the sparking plug hole, and after compressing the spring, remove the split cotters thus freeing the valve. To remove the valves of S.V. models, it is only necessary to compress the spring by pressing on the spring cotter with a screwdriver or other tool and remove the cotter. In the case of non-detachable cylinder heads, valve removal will be facilitated if a piece of wood of suitable thickness is inserted between the valve head and cap.

DECARBONISING. Carefully remove the carbon from the cylinder head, valve pockets and passages. In the case of S.V. machines fitted with non-detachable cylinder heads, a sharp long-handled screwdriver will be found suitable, while rifler files are the best means of scraping carbon from the valve passages. Wipe the cylinder thoroughly with a clean but oily rag, to remove all traces of carbon

from cylinder walls, swill out with paraffin and finally wipe clean.

Scrape all carbon off the top of the piston by means of an old penknife or similar tool, and finish by lightly polishing the piston top with fine emery paper.

GRINDING-IN VALVES. Do not attempt to grind in a badly pitted valve, since excessive valve grinding causes the valve to become pocketed with a consequent loss of power. Send it to the B.S.A. Service Department to be refaced and on its return a slight amount of grinding in will make a good face.

To grind-in a valve proceed as follows:—Lightly smear valve grinding compound on the face of the valve and return it to its seating. On O.H.V. models hold the end of the valve stem by means of the special tool supplied in the kit (on S.V. models use a screwdriver in the slot provided in the valve head) and rotate the valve alternately clockwise and anti-clockwise by a turn of the wrist, at the same time applying pressure to the valve seat. Continue until the valve face shows a smooth surface all the way round. After grinding-in remove all traces of compound from the valve seating.

DECOMPRESSOR—1.74 h.p. Remove the valve by withdrawing the split cotter pin which holds the operating arm at the end of the stem, and examine the seating. If this is slightly pitted, leakage of compression is certain to occur, and the valve should be ground in as above.

Piston Rings. If the piston rings are bright and quite free in their grooves leave them

alone. If the rungs are stick, prise them out very carefully and clean them. Scrape any carbon from the grooves and from the inside and edges of the rings, and then replace. Any ring showing brown patches should be replaced by a new one with the correct gap, which should be .004in. per inch of cylinder diameter. For example, a cylinder of 3in. diameter should be fitted with piston rings of .012in. gap.

Valve Guides. These can be removed or inserted by using a soft copper drift and hammer. When a new guide has been fitted, recut the valve seats with a pilot cutter to ensure concentricity of valve seat and stem.

Valve Springs. These have a tendency to lose their efficiency after a period of use, and it is advisable, therefore, to replace them periodically.

ASSEMBLY AFTER DECARBONISING

Before replacing the cylinder pour a small quantity of engine oil into the crankcase and smear the cylinder walls with oil. Lubricate the valve stems and replace the valves in their respective positions. Smear the piston sides generously with engine oil and also the gudgeon pin, and replace on the connecting rod. **Make sure that the piston is the same way round as it was when taken off and that the joints in the piston rings are on opposite sides of the piston.**

Turn the engine until the big-end is slightly past bottom dead centre. Compress the top piston ring with the finger and slide the cylinder barrel (held in the front angle of the frame) on to the piston. Now compress the lower ring, slide the barrel down to the crankcase and tighten up

the nuts equally. Replace the cylinder head gasket and on S.V. models with detachable cylinder heads, tighten the bolts in the order given in Fig. 23.

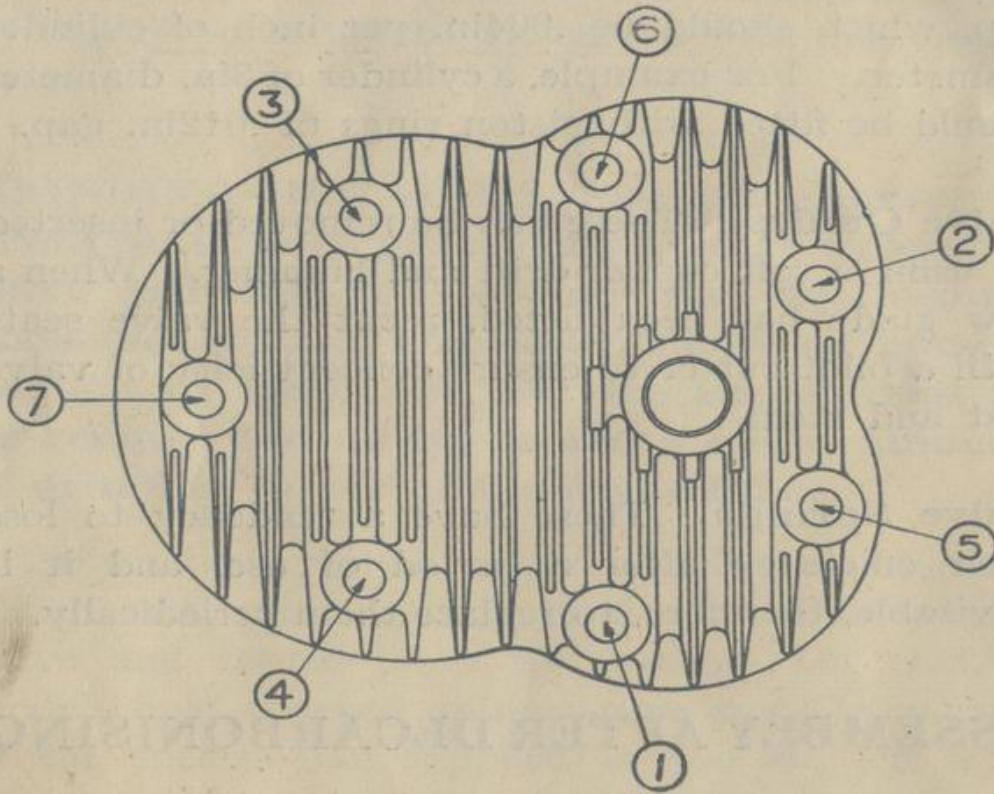

Fig. 23.

On O.H.V. models replace the cylinder head and fit the push rods and tubes loosely in position. Turn the engine until both tappets are down and replace the rocker box, make certain that the tops of the push rod tubes fit in their seatings underneath the box. Tighten down the push rod tubes and rocker box. **Check the tappet clearances and adjust if necessary.** Finally replace the sparking plug, carburetter, exhaust, valve lifter cable (decompressor cable on the 1.74 h.p.), and petrol pipe.

Re-tighten the cylinder head nuts after about 250 miles have been covered.

USEFUL DATA.

Year	TITLE	Model No.	Tappet clearance (ins.)		Ignition Setting	Stand-ard Jet	Needle Position
			Inlet	Exh't			
1930							
1.74	h.p. 3-speed.....	A30-2	—	—		28	1
2.49	h.p.....	B30-3	.004	.006		70	3
2.49	h.p. O.H.V.....	B30-4	.003	.003	Piston at T.D.C. Ignition fully retarded. Contact Breaker points open .003".	70	3
3.49	h.p. S.V.	L30-5	.004	.006		100	2
3.49	h.p. S.V.	L30-6	.004	.006		100	2
4.93	h.p. O.H.V. Light...	S30-19	.003	.003		170	3
4.93	h.p. S.V. Light.....	S30-18	.004	.006		150	3
4.93	h.p. O.H.V. de Luxe	S30-13	.003	.003		170	3
4.93	h.p. O.H.V.	S30-12	.003	.003		170	3
3.49	h.p. O.H.V.	L30-11	.003	.003		140	3
4.93	h.p. S.V. de Luxe...	S30-9	.004	.006		150	3
4.93	h.p. S.V.	S30-7	.004	.006		150	3
5.57	h.p. S.V. de Luxe...	H30-10	.004	.006		150	3
5.57	h.p. S.V.	H30-8	.004	.006		150	3
7.70	h.p. S.V.	E30-14	.005	.005		95	3
9.86	h.p. S.V.	G30-15	.005	.005		110	3
9.86	h.p. S.V. W.T.....	G30-16	.005	.005		110	3
1931							
2.49	h.p. S.V.	B31-1	.004	.006	Piston at T.D.C. Ignition fully retarded. Contact Breaker points open .003".	70	3
2.49	h.p. O.H.V.	B31-2	.003	.003		70	3
2.49	h.p. O.H.V. de Luxe	B31-3	.003	.003		70	3
3.49	h.p. S.V.	L31-4	.004	.006		100	4
3.49	h.p. S.V. de Luxe...	L31-5	.004	.006		100	4
3.49	h.p. O.H.V. de Luxe	L31-6	.003	.003		140	1
4.93	h.p. S.V.	S31-7	.004	.006		150	3
5.57	h.p. S.V. de Luxe...	H31-8	.004	.006		150	3
4.93	h.p. O.H.V.	S31-9	.003	.003		170	2
4.93	h.p. O.H.V. de Luxe	S31-10	.003	.003		170	2
7.70	h.p. S.V.	E31-11	.005	.005		80	2
9.86	h.p. S.V. W.T.....	G31-12	.005	.005		110	3

USEFUL DATA.

Year	TITLE	Model No.	Tappet clearance (ins.)		Ignition Setting	Stand-ard Jet	Needle Position
			Inlet	Exh't			
1932							
2.49	h.p. O.H.V.	B32-1	.003	.003	Piston at T.D.C. Ignition fully retarded. Contact Breaker points open .003".	75	3
3.49	h.p. S.V.	L32-2	.004	.006		85	1
3.49	h.p. O.H.V.	L32-3	.003	.003		120	2
3.49	h.p. S.V. de Luxe...	L32-4	.004	.006		85	1
3.49	h.p. O.H.V. de Luxe	L32-5	.003	.003		140	2
3.49	h.p. O.H.V. Blue Star	L32-5	.003	.003		150	2
4.99	h.p. S.V.	W32-6	.004	.006		140	1
4.99	h.p. O.H.V.	W32-7	.003	.003		170	2
4.99	h.p. O.H.V. Blue Star	W32-7	.003	.003		200	2
4.93	h.p. O.H.V. de Luxe	S32-8	.003	.003		140	2
5.57	h.p. S.V. de Luxe...	H32-9	.004	.006		120	1
9.86	h.p. S.V.	G32-10	.005	.005	110	1	
1933							
2.49	h.p. S.V.	B33-1	.004	.006	Piston at T.D.C. Ignition fully retarded. Contact Breaker points open .003".	70	1
2.49	h.p. O.H.V.	B33-2	.003	.003		75	2
2.49	h.p. O.H.V. Blue Star	B33-3	.003	.003		120	3
3.48	h.p. O.H.V.	R33-4	.003	.003		140	2
3.48	h.p. O.H.V. Blue Star	R33-5	.003	.003		150	2
4.99	h.p. S.V.	W33-6	.004	.008		140	1
4.99	h.p. O.H.V.	W33-7	.003	.003		170	2
4.99	h.p. O.H.V. Blue Star	W33-8	.003	.003		200	2
4.99	h.p. O.H.V. Special	W33-9	Nil	Nil		59 Amac	4
5.95	h.p. S.V.	M33-10	.004	.008		180	3
5.95	h.p. O.H.V.	M33-11	.003	.003		220	2
9.86	h.p. S.V. Light.....	G33-12	.004	.008		110	1
9.86	h.p. S.V. W.T.....	G33-13	.004	.008		110	1

USEFUL DATA.

Year	TITLE	Model No.	Tappet clearance (ins.)		Piston dist. before T.D.C. full ad'nce (ins.)	Standard Jet	Needle Position
			Inlet	Exh't			
1934							
1.49 h.p.	O.H.V.	X34-0	.003	.003	$\frac{5}{16}$	45	—
2.49 h.p.	S.V.	B34-1	.004	.006	$\frac{1}{2}$	70	2
2.49 h.p.	O.H.V.	B34-2	.003	.003	$\frac{1}{2}$	75	2
2.49h.p.	O.H.V. Blue Star	B34-3	.003	.003	$\frac{1}{2}$	45	4
2.49 h.p.	O.H.V. Sports	B34-17	.003	.003	$\frac{1}{2}$	85	3
3.48 h.p.	O.H.V.	R34-4	.003	.003	$\frac{1}{2}$	140	2
3.48h.p.	O.H.V. Blue Star	R34-5	.003	.003	$\frac{5}{8}$	150	2
3.48 h.p.	O.H.V. Special	R34-6	Nil	Nil	$\frac{5}{8}$	49	4
4.99 h.p.	S.V.	W34-7	.004	.008	$\frac{7}{16}$	140	1
4.99 h.p.	O.H.V.	W34-8	.003	.003	$\frac{7}{16}$	170	2
4.99h.p.	O.H.V. Blue Star	W34-9	.003	.003	$\frac{5}{8}$	200	2
4.99 h.p.	O.H.V. Special	W34-10	Nil	Nil	$\frac{5}{8}$	59	4
4.98h.p.	O.H.V. Vee Twin	J34-11	.002	.002	ft. cyl. $\frac{9}{16}$	80	2
5.95 h.p.	S.V.	M34-12	.004	.008	$\frac{5}{8}$	180	3
5.95 h.p.	O.H.V.	M34-13	.003	.003	$\frac{5}{8}$	220	2
9.86 h.p.	W.T.	G34-14	.004	.008	ft. cyl. $\frac{9}{16}$	180	3
1935							
1.49 h.p.	O.H.V.	X35-0	.003	.003	$\frac{5}{16}$	45	—
2.49 h.p.	S.V.	B35-1	.004	.006	$\frac{1}{2}$	70	2
2.49 h.p.	O.H.V.	B35-2	.003	.003	$\frac{1}{2}$	75	2
2.49 h.p.	O.H.V. de Luxe	B35-3	.003	.003	$\frac{1}{2}$	110	1
3.48 h.p.	O.H.V. de Luxe	R35-4	.003	.003	$\frac{1}{2}$	140	2
3.48h.p.	O.H.V. Blue Star	R35-5	.003	.003	$\frac{5}{8}$	150	2
4.99 h.p.	S.V.	W35-6	.004	.008	$\frac{7}{16}$	140	1
4.99 h.p.	O.H.V.	W35-7	.003	.003	$\frac{7}{16}$	170	2
4.99h.p.	O.H.V. Blue Star	W35-8	.003	.003	$\frac{5}{8}$	200	2
4.99 h.p.	O.H.V. Special	W35-9	Nil	Nil	$\frac{5}{8}$	59	4
5.95 h.p.	S.V.	M35-10	.004	.008	$\frac{5}{8}$	180	3
5.95 h.p.	O.H.V.	M35-11	.003	.003	$\frac{5}{8}$	220	2
4.98h.p.	O.H.V. Vee Twin	J35-12	.002	.002	$\frac{9}{16}$	80	2
9.86 h.p.	Vee Twin	G35-14	.004	.008	$\frac{9}{16}$	180	3

USEFUL DATA.

Year	TITLE	Model No.	Tappet clearance (ins.)		Piston dist. before T.D.C. full ad'nce (ins.)	Stand-ard Jet	Needle Position
			Inlet	Exh't			
1936							
	1.49 h.p. O.H.V.	X0	.003	.003	$\frac{5}{16}$	45	—
	2.49 h.p. S.V.	B1	.004	.006	$\frac{1}{4}$	70	2
	2.49 h.p. O.H.V.	B2	.003	.003	$\frac{1}{4}$	75	2
	2.49 h.p. O.H.V. Light de Luxe.....	B18	.003	.003	$\frac{1}{4}$	75	2
	2.49 h.p. O.H.V. de Luxe	B3	.002	.002	$\frac{1}{2}$	110	3
	3.48 h.p. O.H.V. de Luxe	R4	.002	.002	$\frac{1}{2}$	140	2
	3.48 h.p. O.H.V. Competition	R19	.002	.002	$\frac{1}{2}$	140	2
	3.48 h.p. O.H.V.	R17	.003	.003	$\frac{5}{8}$	140	2
	3.48 h.p. O.H.V. New Blue Star	R20	.003	.003	$\frac{5}{8}$	150	2
	4.96 h.p. O.H.V. New Blue Star	Q21	.003	.003	$\frac{5}{8}$	190	3
	4.96 h.p. O.H.V. Empire Star.....	Q8	.003	.003	$\frac{5}{8}$	190	3
	3.48 h.p. O.H.V. Empire Star.....	R5	.003	.003	$\frac{5}{8}$	150	2
	4.99 h.p. S.V.	W6	.004	.008	$\frac{7}{16}$	140	1
	4.96 h.p. O.H.V.	Q7	.003	.003	$\frac{9}{16}$	170	2
	4.98h.p. O.H.V. Vee Twin	J12	.002	.002	ft. cyl. $\frac{9}{16}$	80	2
	5.95 h.p. S.V.	M10	.004	.008	$\frac{9}{16}$	130	2
	7.48h.p. O.H.V. Vee Twin	Y13	.002	.002	ft. cyl. $\frac{9}{16}$	160	3
	9.86 h.p. S.V. Vee Twin	G14	.004	.008	ft. cyl. $\frac{9}{16}$	160	1

www.hpw.it

PROPRIETARY INSTRUMENTS, FITTINGS, AND ACCESSORIES.

No expense is spared to secure as standard equipment the most suitable and highest quality instruments and accessories. Nevertheless, the Company's guarantee does not cover such parts, and in the event of trouble being experienced the parts in question should be returned to and claims made direct on the actual manufacturers, who will deal with them on the terms of their respective guarantees, as follows:

Tyres: Messrs. Dunlop Rubber Co. Ltd., Fort Dunlop, Birmingham.

Saddles: Messrs. Herbert Terry & Sons Ltd. Redditch.

Electrical Equipment: Messrs. Joseph Lucas Ltd., Birmingham.

Electric Horns: Messrs. Joseph Lucas Ltd., Birmingham.

Speedometers and Clocks: Messrs. S. Smith and Sons (M.A.) Ltd., Cricklewood, London.

Carburettors and Twist Grips: Messrs. Amalgamated Carburettors Ltd., Perry Barr, Birmingham.

Tell-tale Buttons: Messrs. Rotherham & Sons Ltd., Coventry.

Grease Guns: Messrs. Tecalemit Ltd., Great West Road, Brentford, Middlesex.

SPECIAL NOTE.

Prompt attention to all claims under guarantee will be ensured if your covering letter gives—

- (1) Make, year, and model of motor cycle.
- (2) Date of purchase and name of Dealer from whom obtained.

LUCAS SERVICE DEPOTS.

In the event of any difficulty with any part of the equipment, no matter how trivial, we shall be only too pleased to give every assistance possible. The best course to adopt is to call at the nearest Lucas Service Depot (the addresses of which are given below), when the equipment can be examined as a whole. The depots are not only at your disposal for repairs, overhauls and adjustments, but to give free advice. If it is necessary, however, to communicate, or when ordering spare parts, always give the type and number of the unit in question, the make, and if possible the date of the Motor Cycle on which it is fitted.

BELFAST	3/5, Calvin Street, Mountpottinger
Telephone: Belfast 57291 (3 lines)	Telegrams: "Servdep, Belfast"
BIRMINGHAM, 18	Great Hampton Street
Telephone: Central 8401 (10 lines)	Telegrams: "Lucas, Birmingham"
BRIGHTON, 4	85, Old Shoreham Road, Hove
Telephone: Hove 1146 (4 lines)	Telegrams: "Luserv, Brighton"
BRISTOL	345, Bath Road
Telephone: Bristol 76001 (4 lines)	Telegrams: "Kingly, Bristol"
CARDIFF	54a, Penarth Road
Telephone: Cardiff 4603 (4 lines)	Telegrams: "Lucas, Cardiff"
COVENTRY	Priory Street
Telephone: Coventry 3068	Telegrams: "Lucas, Coventry"
DUBLIN Portland Street North, North Circular Road	
Telephone: Drumcondra 434 (4 lines)	Telegrams: "Luserv, Dublin"
EDINBURGH, 11	60, Stevenson Road, Gorgie
Telephone: Edinburgh 62921 (4 lines)	Telegrams: "Luserv, Edinburgh"
GLASGOW	227/229, St. George's Road
Telephone: Douglas 3075 (5 lines)	Telegrams: "Lucas, Glasgow"
LEEDS	64, Roseville Road
Telephone: Leeds 28591 (5 lines)	Telegrams: "Luserdep, Leeds"
LIVERPOOL, 13	450/456, Edge Lane
Telephone: Old Swan 1408 (3 lines)	Telegrams: "Luserv, Liverpool"
LONDON	Dordrecht Road, Acton Vale, W.3
Telephone: Shepherds Bush 3160 (10 lines)	Grams: "Dynomagna, Act, London"
LONDON	757/759, High Road, Leyton, E.10
Telephone: Leytonstone 3361 (3 lines)	Grams: "Luserdep, Walt, London"
LONDON	155, Merton Road, Wandsworth, S.W.18
Telephone: Putney 5131 (5 lines)	Telegrams: "Luserv, Put, London"
MANCHESTER	Talbot Road, Stretford
Telephone: Longford 1101 (5 lines)	Telegrams: "Lucas, Stretford"
NEWCASTLE-ON-TYNE, 2	64/66, St. Mary's Place
Telephone: Newcastle 25571 (3 lines)	Telegrams: "Motolite, Newcastle-on-Tyne"

LIST OF B.S.A. STOCKISTS.

FOR SERVICE APPLY EITHER WHERE THE VEHICLE WAS PURCHASED
OR TO THE LOCAL B.S.A. DEALER, OR TO ANY OF THE FOLLOWING
B.S.A. MOTOR CYCLE SPARE PARTS STOCKISTS.

<i>Town.</i>	<i>Name of Stockist.</i>	<i>Address.</i>	<i>Telephone No.</i>	<i>Telegraphic Address.</i>
Aberdeen	J. Dawson	24-26, Thistle Street	1272	
Aldershot	Phillips Bros.	Birchett Road and Cranmore Lane.	300	Phillips, Cycles, Aldershot.
Banbury	Trinder Bros.	3, Broad Street	146	Trinder, 146, Banbury.
Bedford	The Imperial Cycle Co.	58, St. Loyes	2374	
Belfast	W. J. Chambers	106, Donegall Pass	2263	Fastmote, Belfast.
Biggleswade	Bryants	72, Shortmead Street	108	
Birkenhead	H. J. Marston	50, Argyle Street	2213	Notsram, Birkenhead.
Birmingham	County Cycle & Motor Co. Ltd.	301, Broad Street	Midland 2670	Comocyco, Birmingham.
„ (Aston)	Falcon Cycle & Motor Depot (E. Newell).	54, Lozells Road	Northern 505	
„ (Balsall H.)	Shovellbottom's	346/352, Ladypool Rd.		
„ (Edgbaston 17)	Chas. E. Cope & Sons Ltd.	15, Upper Hagley Road	Bearwood 1943	
„ (Hay Mills)	H. Bird & Sons	1045, Coventry Road	Victoria 651	
„ (Rubery)	Owen's Garage	New Road	Rubery 3	Owen, Rubery, Birmingham.
„ (Small Heath).	Scotts	545, Coventry Road	Victoria 372	
„ (Sparkhill).	A. Watkins	550 & 565, Stratford Rd.	Victoria 946	
Blackburn	Shuttleworth & Geldart	15, Great Bolton Street	6678	
Blackpool	J. Hall	143, Church Street	795	
Bournemouth	Craze Bros.	475, Christchurch Rd., Boscombe.	Boscombe 63	
„	S. Priestley	35, Seamoor Road	834	Priestley, Bournemouth.
Bradford	C. Sidney Ltd.	Blind Institute Buildings, Upper Piccadilly.	3116	
Bridgwater	Anderson & Wall	18, St. Mary Street	116	Service, Bridgwater.
Brighton	Bridgers	20, Gloucester Place	Brighton 5281	
Bristol	S. J. Fair	201, Cheltenham Road	2238	
Bury	Arthur Coyle	30-32, Walmersley Road	714	
Cambridge	King & Harper	6 and 7, Bridge Street	1600	Motors, Cambridge.
Canterbury	G. R. Barrett & Son	30, St. Peter Street	386	Barrett Motors, Canterbury.
Cardiff	CarDistributors(Cardiff) Ltd.	155, City Road	3422	
Carlisle	W. T. Tiffen	Irishgate Brow	314	Tiffen, Irishgate, Carlisle.
Carmarthen	W. Edwards & Sons	Towy Garage	682	Edwards' Garage Carmarthen.

www.bmw.it

List of B.S.A. Stockists—continued.

Town.	Name of Stockist.	Address.	Telephone No.	Telegraphic Address.
Chapel-en-le-Frith.	Lomas Bros...	Newfield Garage ..	Whaley Bridge 100	
		[Tel.: Lomas Bros., Chapel-en-le-Frith.		
Chatham ..	H. G. Russell ..	Medway Garage, Medway Street.	2609	
Chelmsford ..	H. T. Hadler ..	New Street ..	227	Hadler, Chelmsford.
Cheltenham ..	Leslie Paynter ..	Bath Street ..	2887	Paynter's Garage, [Bath Street, Cheltenham.
Chester ..	Davies Bros...	34, Bridge Street ..	510	
Colchester ..	The Motor Cycle and Light Car Depot.	119, High Street ..	2632	Medcalf, Colchester.
Coventry ..	Coventry Motor Mart Ltd.	London Road ..	3200	Coventry Motor Mart.
Croydon(West)	Godfreys Ltd. ..	228/234, London Road	Croydon 3641/2	Gofrable, London.
Derby ..	Kay & Scampton ..	14, Sadlergate ..	Derby 1131	Kay, Sadlergate, Derby.
Doncaster ..	W. E. Clark & Co. ..	27 & 29, Station Road, ..	176	Cars, Doncaster .
Dorchester ..	Tilley's ..	31, South Street ..	14	Motors, Dorchester .
Dunstable ..	B. G. England ..	Half Moon Hill, Watling Street.	207	
Eastbourne ..	Bradshaw's ..	10, Terminus Road ..	1292	
Edinburgh ..	Alexander & Co. ..	113-115, Lothian Road .	21176	Motorcycles, Edinburgh.
Enfield ..	D. J. Shepherd & Co. (Enfield) Ltd., ..	'Mountjoy' Motor Wks., Enfield Highway, ..	1231	
Evesham ..	Frank Morrall Ltd. ..	Central Garage, 20, Port Street.	54	
Exeter ..	Wessex Garage Co. ..	18-22, Longbrook Street.	2342	Wessex Garage, Exeter.
Frome ..	P. Difazio ..	25, Catherine Street ..	2121	Difazio, Frome
Gateshead ..	O. Carmichael & Son ..	81-83, High West Street	15	
Glasgow ..	Bell Bros. ..	223, St. George's Road .	Douglas 258	Motobike, Glasgow .
" ..	Alexander & Co. ..	272-280, Great Western Road.	Douglas 3880	Alexmoto, Glasgow.
Gloucester ..	T. E. Harper ..	1, Worcester Street ..	1187	
Guildford ..	E. Pascall ..	107, Woodbridge Road	Guildford 255	
Halifax ..	Halifax Motor Exchange	25, Horton Street ..	1400	Perfection, Halifax.
Hampton-in-Arden.	J. Pearson ..	Barston ..	Hampton-in-Arden 30	
Harrogate ..	H. Acklam ..	11, Bower Road ..	5125	
Haywards H'th	Dinnage's Garages Ltd.	Wivelsfield Road ..	593	
Hereford ..	A. Kear & Co. ..	52b, Commercial Street.	7239	Kear, Hereford.

www.bow.it

List of B.S.A. Stockists—continued.

Town.	Name of Stockist.	Address.	Telephone No.	Telegraphic Address.
Hitchin	J. Chalkley & Sons	Brand Street.. ..	44	Chalkley's, Hitchin.
Hove	Bradshaws	6, Western Road	Hove 4124	
Huddersfield..	Earnshaws	Manchester Road.. ..	1232	
Hull.. ..	A. E. Brown.. ..	47½-48, Witham	Central 4162	
Ipswich	Revett's... ..	Barrack Corner Garage and St. Matthew's St.	2822	Revetts, Motors. Ipswich.
Kingston-on- Thames.	H. Taylor & Co.	135/7, London Road	1263/4	Dynametro, Kingston.
Launceston ..	J. Wooldridge & Son	Western Road	21	Wooldridge, Launceston.
Leeds	Watson, Cairns & Co. Ltd.	Lower Briggate	23379	Watson Cairns, Briggate, Leeds.
Leicester	E. W. Campion & Sons	Welford Place	58054	
Lincoln	West's (Lincoln) Ltd... ..	115c, High Street	762	West's Garage, Lincoln.
Liverpool	Cundle's	41, Byrom Street.. ..	Bank 6160	Seldnuc, Liverpool.
London, S.E.15	Boyer & Bentley	118, Peckham Rye	New Cross 3032	
„ W.1 ..	Godfrey's Ltd.	366-368, Euston Road.. ..	Euston 2644	Gofrabike, London
„ E.C.2 ..	J. Grose Ltd.	4, Old Jewry, Cheapside	Central 0166	Jogrospur, Phone, London
„ N.7 ..	J. Grose Ltd.	255-257, Holloway Rd. .	Northern 1297	
„ S.E.6..	E. Parks & Son	5 and 6, Central Parade, Catford.	Lee Green 2011	Mocycparts, Catgreen, London.
„ S.E.18.	Clare & Co. Ltd.	125, Woolwich High Street.	Woolw ch 174	
„ W.12..	Turner's Stores	81-83, Goldhawk Road	Shepherd's Bush 2436	
„ E.7 ..	Lovett's Ltd.	418, Romford Road, Forest Gate.	Grangewood 1234	Lovetmoto. London.
„ S.W.11	Owen Bros.	19, Battersea Rise, Clapham Common.	Battersea 1299	
„ (Twickenham)	C.A Blay	192, Heath Road	Popesgrove 2103	
Lowestoft ..	Taylor Bros... ..	75, London Road	510	
Luton	F. H. Moss	Park Street	1792	
Maidstone	Anstey Ltd.	30-34, Stone Street	432	Anstey 432, Maidstone.

www.bpw.it

List of B.S.A. Stockists—continued.

Town.	Name of Stockist.	Address.	Telephone No.	Telegraphic Address.
Manchester ..	W. H. Jones	415, Bury New Road, Market Place, Higher B'ton.	Hr. B'ton. 2978	
" ..	Colmore Depot	17, Watson Street ..		Coldep, Manchester.
" ..	Tom Davies	229, Deansgate	B'kfriars 0536	
" ..	Stretford Garage	1073, Chester Road, Stretford.	Longford 1998	
Middlesbrough	Pallister, Yare & Cobb, Ltd.	134, Marton Road ..	2873	Payacob, Middlesbrough.
Nelson	Wilde & Co... ..	95 & 97, Manchester Rd.	524	
Newcastle-on-Tyne.	Dene (Newcastle) Motor Co. Ltd.	Haymarket	N'castle 21837	Ened, New- castle-on-Tyne.
Northampton .	P. C. Spokes	1, Henry Street	1160	
Norton (Malton, Yorks.)	Bower's Motor Exchange	Church Street	Malton 176	Bower, Malton.
Norwich	H. Chapman	42, Duke Street	921	Chapman, Duke Street, Norwich.
Nottingham ..	E. W. Champion & Sons	Station Street	2961	
Oxford	Laytons of Oxford ..	New Road	3381	Integrity, Oxford.
Perth	M. Shaw & Sons	22, Mill Street, and 137-143, High Street.	483	Shaw's Garage Perth.
Peterborough .	Burrows Bros.	57, Westgate	154	
Plymouth	A. E. Snell (Mrs.) ..	95/7, Old Town Street .	1706	Tyres, Plymouth.
Portsmouth ..	G. E. Minnell	Russell Street		
Preston	Loxham's Garages Ltd.	Charnley Street, Fisher- gate.	4242	Loxham's, Preston.
Pulborough (Sussex).	Gray & Rowsell	Fittleworth Station, Burygate.	Bury 4 (Sussex)	
Reading	Fortescue Bros. Ltd. ..	1 and 2, West Street ..	1143	
Redhill	The Redhill Motor and Cycle Works.	50, Brighton Road ..	327	
Rhyl	Nelson's	39, Queen Street	130	Nelson's Garage, Rhyl.
St. Austell ..	S. H. Kellaway & Sons	South Street Garage ..	102	
Salisbury	W. Rowland & Sons ..	86-106, Castle Street ..	170	Motors, Salisbury.
Sheffield	Walter Wragg Ltd. ..	Wellington Street ..	26098	Wragg, Sheffield 26098.
Sherborne	Sheppards Garage (Sherborne) Ltd.	Sherborne Garage, South Street.	85	Dyer, Sherborne.
Shetland	Thomson's Motor Gar- age & Marine Engine	Esplanade, Lerwick ..	85	Thomson's Gar- age, Lerwick.

INDEX

	<i>Page</i>		<i>Page</i>
Adjustments :		Lubrication :	
Brakes	21	Chains.....	17
Clutch.....	28	Cycle Parts	16
Clutch operation	22	Dry Sump System...	14
Front Chain	28	Gearbox	18
Front Fork	22	Gravity Feed System	8-12
Gear Change (foot)...	35	Petrol System (1.74	
Gear Change (hand)...	38	h.p.)	4
Hubs	23	Pilgrim Oil Pump.....	14
Hubs (quickly detach-		Push Rod Ends.....	16
able)	24	Rockers	16
Magneto Timing	34	Sump System	5
Magneto Chain.....	35		
Rear Chain	33	Filling-up	1
Rockers	21		
Steering Head	23	Gear Changing.....	3
Tappet Clearances ...	18		
Valve Timing	34	Starting	2
Controls	2	Sidecar Alignment ...	38
Clutch	28	Sparkling Plug	36
Decarbonisation :			
Assembly after Decar-			
bonisation	43		
Decarbonising	41		
Decompressor (1.74 h.p.)	42		
Dismantling	40		
Grinding-in Valves ...	42		
Piston Rings.....	42		
Valve Guides.....	43		
Valve Springs	43		

G. Egden.

91 Riddings Rd

Limerly

Altrincham

Cheshire

